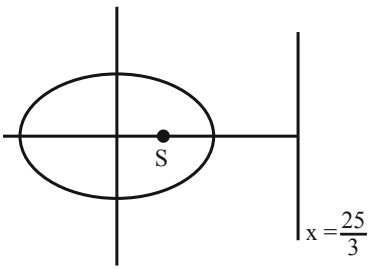

(Held On Tuesday 30th January, 2024)
TIME : 3 : 00 PM to 6 : 00 PM

MATHEMATICS	TEST PAPER WITH SOLUTION
SECTION-A	
<p>1. Consider the system of linear equations $x + y + z = 5$, $x + 2y + \lambda^2 z = 9$, $x + 3y + \lambda z = \mu$, where $\lambda, \mu \in \mathbb{R}$. Then, which of the following statement is NOT correct? (1) System has infinite number of solution if $\lambda = 1$ and $\mu = 13$ (2) System is inconsistent if $\lambda = 1$ and $\mu \neq 13$ (3) System is consistent if $\lambda \neq 1$ and $\mu = 13$ (4) System has unique solution if $\lambda \neq 1$ and $\mu \neq 13$ Ans. (4)</p> <p>Sol.</p> $\begin{vmatrix} 1 & 1 & 1 \\ 1 & 2 & \lambda^2 \\ 1 & 3 & \lambda \end{vmatrix} = 0$ $\Rightarrow 2\lambda^2 - \lambda - 1 = 0$ $\lambda = 1, -\frac{1}{2}$ $\begin{vmatrix} 1 & 1 & 5 \\ 2 & \lambda^2 & 9 \\ 3 & \lambda & \mu \end{vmatrix} = 0 \Rightarrow \mu = 13$ <p>Infinite solution $\lambda = 1$ & $\mu = 13$ For unique solⁿ $\lambda \neq 1$ For no solⁿ $\lambda = 1$ & $\mu \neq 13$ If $\lambda \neq 1$ and $\mu \neq 13$ Considering the case when $\lambda = -\frac{1}{2}$ and $\mu \neq 13$ this will generate no solution case</p> <p>2. For $\alpha, \beta \in (0, \frac{\pi}{2})$, let $3\sin(\alpha+\beta) = 2\sin(\alpha-\beta)$ and a real number k be such that $\tan\alpha = k \tan\beta$. Then the value of k is equal to : (1) $-\frac{2}{3}$ (2) -5 (3) $\frac{2}{3}$ (4) 5 Ans. Bonus</p>	<p>Sol. $3\sin\alpha \cos\beta + 3\sin\beta \cos\alpha$ $= 2\sin\alpha \cos\beta - 2\sin\beta \cos\alpha$ $5\sin\beta \cos\alpha = -\sin\alpha \cos\beta$ $\tan\beta = -\frac{1}{5} \tan\alpha$ $\tan\alpha = -5\tan\beta$ Not possible as $\tan\alpha, \tan\beta$ are positive \Rightarrow Data inconsistent</p> <p>3. Let $A(\alpha, 0)$ and $B(0, \beta)$ be the points on the line $5x + 7y = 50$. Let the point P divide the line segment AB internally in the ratio $7 : 3$. Let $3x - 25 = 0$ be a directrix of the ellipse $E: \frac{x^2}{a^2} + \frac{y^2}{b^2} = 1$ and the corresponding focus be S. If from S, the perpendicular on the x-axis passes through P, then the length of the latus rectum of E is equal to (1) $\frac{25}{3}$ (2) $\frac{32}{9}$ (3) $\frac{25}{9}$ (4) $\frac{32}{5}$ Ans. (4) $A = (10, 0)$ Sol. $B = (0, \frac{50}{7})$ } $P = (3, 5)$</p>  <p>$ae = 3$ $\frac{a}{e} = \frac{25}{3}$ $a = 5$ $b = 4$ Length of LR = $\frac{2b^2}{a} = \frac{32}{5}$</p>

4. Let $\vec{a} = \hat{i} + \alpha\hat{j} + \beta\hat{k}$, $\alpha, \beta \in \mathbb{R}$. Let a vector \vec{b} be such that the angle between \vec{a} and \vec{b} is $\frac{\pi}{4}$ and $|\vec{b}|^2 = 6$, If $\vec{a} \cdot \vec{b} = 3\sqrt{2}$, then the value of $(\alpha^2 + \beta^2)|\vec{a} \times \vec{b}|^2$ is equal to
- (1) 90 (2) 75
(3) 95 (4) 85

Ans. (1)

Sol. $|\vec{b}|^2 = 6$; $|\vec{a}| |\vec{b}| \cos\theta = 3\sqrt{2}$

$$|\vec{a}|^2 |\vec{b}|^2 \cos^2 \theta = 18$$

$$|\vec{a}|^2 = 6$$

$$\text{Also } 1 + \alpha^2 + \beta^2 = 6$$

$$\alpha^2 + \beta^2 = 5$$

to find

$$(\alpha^2 + \beta^2) |\vec{a}|^2 |\vec{b}|^2 \sin^2 \theta$$

$$= (5)(6)(6) \left(\frac{1}{2}\right)$$

$$= 90$$

5. Let $f(x) = (x+3)^2(x-2)^3$, $x \in [-4, 4]$. If M and m are the maximum and minimum values of f , respectively in $[-4, 4]$, then the value of $M - m$ is :
- (1) 600 (2) 392
(3) 608 (4) 108

Ans. (3)

Sol. $f'(x) = (x+3)^2 \cdot 3(x-2)^2 + (x-2)^3 \cdot 2(x+3)$

$$= 5(x+3)(x-2)^2(x+1)$$

$$f'(x) = 0, x = -3, -1, 2$$

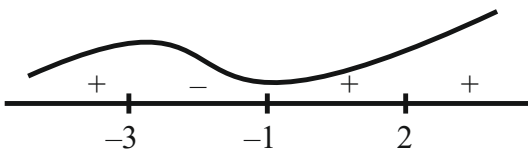

$$f(-4) = -216$$

$$f(-3) = 0, f(4) = 49 \times 8 = 392$$

$$M = 392, m = -216$$

$$M - m = 392 + 216 = 608$$

$$\text{Ans} = '3'$$

6. Let a and b be two distinct positive real numbers. Let 11th term of a GP, whose first term is a and third term is b , is equal to p^{th} term of another GP, whose first term is a and fifth term is b . Then p is equal to
- (1) 20 (2) 25
(3) 21 (4) 24

Ans. (3)

Sol. 1st GP $\Rightarrow t_1 = a, t_3 = b = ar^2 \Rightarrow r^2 = \frac{b}{a}$

$$t_{11} = ar^{10} = a(r^2)^5 = a \cdot \left(\frac{b}{a}\right)^5$$

$$2^{\text{nd}} \text{ G.P.} \Rightarrow T_1 = a, T_5 = ar^4 = b$$

$$\Rightarrow r^4 = \left(\frac{b}{a}\right) \Rightarrow r = \left(\frac{b}{a}\right)^{1/4}$$

$$T_p = ar^{p-1} = a \left(\frac{b}{a}\right)^{\frac{p-1}{4}}$$

$$t_{11} = T_p \Rightarrow a \left(\frac{b}{a}\right)^5 = a \left(\frac{b}{a}\right)^{\frac{p-1}{4}}$$

$$\Rightarrow 5 = \frac{p-1}{4} \Rightarrow p = 21$$

7. If $x^2 - y^2 + 2hxy + 2gx + 2fy + c = 0$ is the locus of a point, which moves such that it is always equidistant from the lines $x + 2y + 7 = 0$ and $2x - y + 8 = 0$, then the value of $g + c + h - f$ equals
- (1) 14 (2) 6
(3) 8 (4) 29

Ans. (1)

Sol. Cocus of point $P(x, y)$ whose distance from

Gives

$$X + 2y + 7 = 0 \text{ \& } 2x - y + 8 = 0 \text{ are equal is}$$

$$\frac{x+2y+7}{\sqrt{5}} = \pm \frac{2x-y+8}{\sqrt{5}}$$

$$(x+2y+7)^2 - (2x-y+8)^2 = 0$$

Combined equation of lines

$$(x - 3y + 1)(3x + y + 15) = 0$$

$$3x^2 - 3y^2 - 8xy + 18x - 44y + 15 = 0$$

$$x^2 - y^2 - \frac{8}{3}xy + 6x - \frac{44}{3}y + 5 = 0$$

$$x^2 - y^2 + 2hxy + 2gx + 2fy + c = 0$$

$$h = \frac{4}{3}, g = 3, f = -\frac{22}{3}, c = 5$$

$$g + c + h - f = 3 + 5 - \frac{4}{3} + \frac{22}{3} = 8 + 6 = 14$$

8. Let \vec{a} and \vec{b} be two vectors such that $|\vec{b}| = 1$ and $|\vec{b} \times \vec{a}| = 2$. Then $|(\vec{b} \times \vec{a}) - \vec{b}|^2$ is equal to

(1) 3

(2) 5

(3) 1

(4) 4

Ans. (2)

Sol. $|\vec{b}| = 1$ & $|\vec{b} \times \vec{a}| = 2$

$$(\vec{b} \times \vec{a}) \cdot \vec{b} = \vec{b} \cdot (\vec{b} \times \vec{a}) = 0$$

$$|(\vec{b} \times \vec{a}) - \vec{b}|^2 = |\vec{b} \times \vec{a}|^2 + |\vec{b}|^2$$

$$= 4 + 1 = 5$$

9. Let $y = f(x)$ be a thrice differentiable function in $(-5, 5)$. Let the tangents to the curve $y = f(x)$ at $(1, f(1))$ and $(3, f(3))$ make angles $\frac{\pi}{6}$ and $\frac{\pi}{4}$, respectively with positive x -axis. If

$$27 \int_1^3 ((f'(t))^2 + 1) f''(t) dt = \alpha + \beta \sqrt{3}$$

where α, β are integers, then the value of $\alpha + \beta$ equals

(1) -14

(2) 26

(3) -16

(4) 36

Ans. (2)

Sol. $y = f(x) \Rightarrow \frac{dy}{dx} = f'(x)$

$$\left. \frac{dy}{dx} \right|_{(1, f(1))} = f'(1) = \tan \frac{\pi}{6} = \frac{1}{\sqrt{3}} \Rightarrow f'(1) = \frac{1}{\sqrt{3}}$$

$$\left. \frac{dy}{dx} \right|_{(3, f(3))} = f'(3) = \tan \frac{\pi}{4} = 1 \Rightarrow f'(3) = 1$$

$$27 \int_1^3 ((f'(t))^2 + 1) f''(t) dt = \alpha + \beta \sqrt{3}$$

$$I = \int_1^3 ((f'(t))^2 + 1) f''(t) dt$$

$$f'(t) = z \Rightarrow f''(t) dt = dz$$

$$z = f'(3) = 1$$

$$z = f'(1) = \frac{1}{\sqrt{3}}$$

$$I = \int_{1/\sqrt{3}}^1 (z^2 + 1) dz = \left(\frac{z^3}{3} + z \right) \Big|_{1/\sqrt{3}}^1$$

$$= \left(\frac{1}{3} + 1 \right) - \left(\frac{1}{3} \cdot \frac{1}{3\sqrt{3}} + \frac{1}{\sqrt{3}} \right)$$

$$= \frac{4}{3} - \frac{10}{9\sqrt{3}} = \frac{4}{3} - \frac{10}{27}\sqrt{3}$$

$$\alpha + \beta \sqrt{3} = 27 \left(\frac{4}{3} - \frac{10}{27}\sqrt{3} \right) = 36 - 10\sqrt{3}$$

$$\alpha = 36, \beta = -10$$

$$\alpha + \beta = 36 - 10 = 26$$

10. Let P be a point on the hyperbola $H: \frac{x^2}{9} - \frac{y^2}{4} = 1$,

in the first quadrant such that the area of triangle formed by P and the two foci of H is $2\sqrt{13}$. Then, the square of the distance of P from the origin is

(1) 18

(2) 26

(3) 22

(4) 20

Ans. (3)

Sol.

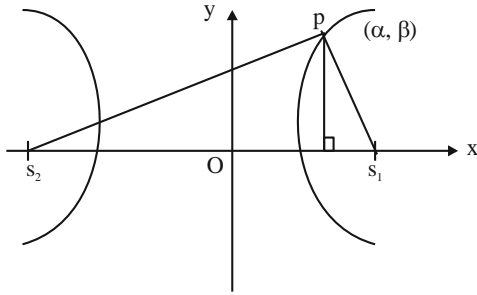

$$\frac{x^2}{9} - \frac{y^2}{4} = 1$$

$$a^2 = 9, b^2 = 4$$

$$b^2 = a^2(e^2 - 1) \Rightarrow e^2 = 1 + \frac{b^2}{a^2}$$

$$e^2 = 1 + \frac{4}{9} = \frac{13}{9}$$

$$e = \frac{\sqrt{13}}{3} \Rightarrow s_1 s_2 = 2ae = 2 \times 3 \times \frac{\sqrt{13}}{3} = 2\sqrt{13}$$

$$\text{Area of } \Delta PS_1 S_2 = \frac{1}{2} \times \beta \times s_1 s_2 = 2\sqrt{13}$$

$$\Rightarrow \frac{1}{2} \times \beta \times (2\sqrt{13}) = 2\sqrt{13} \Rightarrow \beta = 2$$

$$\frac{\alpha^2}{9} - \frac{\beta^2}{4} = 1 \Rightarrow \frac{\alpha^2}{9} - 1 = 1 \Rightarrow \alpha^2 = 18 \Rightarrow \alpha = 3\sqrt{2}$$

$$\begin{aligned} \text{Distance of P from origin} &= \sqrt{\alpha^2 + \beta^2} \\ &= \sqrt{18 + 4} = \sqrt{22} \end{aligned}$$

11. Bag A contains 3 white, 7 red balls and bag B contains 3 white, 2 red balls. One bag is selected at random and a ball is drawn from it. The probability of drawing the ball from the bag A, if the ball drawn is white, is :

(1) $\frac{1}{4}$ (2) $\frac{1}{9}$

(3) $\frac{1}{3}$ (4) $\frac{3}{10}$

Ans. (3)

	A	B
Sol. E_1 : A is selected	3W 7R	3W 2R

E_2 : B is selected

E : white ball is drawn

$P(E_1/E) =$

$$\begin{aligned} \frac{P(E) \cdot P(E/E_1)}{P(E_1) \cdot P(E/E_1) + P(E_2) \cdot P(E/E_2)} &= \frac{\frac{1}{2} \times \frac{3}{10}}{\frac{1}{2} \times \frac{3}{10} + \frac{1}{2} \times \frac{3}{5}} \\ &= \frac{3}{3+6} = \frac{1}{3} \end{aligned}$$

12. Let $f : \mathbb{R} \rightarrow \mathbb{R}$ be defined $f(x) = ae^{2x} + be^x + cx$. If $f(0) = -1$, $f'(\log_e 2) = 21$ and

$\int_0^{\log_e 4} (f(x) - cx) dx = \frac{39}{2}$, then the value of $|a+b+c|$ equals :

(1) 16 (2) 10

(3) 12 (4) 8

Ans. (4)

Sol. $f(x) = ae^{2x} + be^x + cx$ $f(0) = -1$

$$a + b = -1$$

$f'(x) = 2ae^{2x} + be^x + c$ $f'(\ln 2) = 21$

$$8a + 2b + c = 21$$

$$\int_0^{\ln 4} (ae^{2x} + be^x) dx = \frac{39}{2}$$

$$\left[\frac{ae^{2x}}{2} + be^x \right]_0^{\ln 4} = \frac{39}{2} \Rightarrow 8a + 4b - \frac{a}{2} - b = \frac{39}{2}$$

$$15a + 6b = 39$$

$$15a - 6a - 6 = 39$$

$$9a = 45 \Rightarrow a = 5$$

$$b = -6$$

$$c = 21 - 40 + 12 = -7$$

$$a + b + c = -8$$

$$|a + b + c| = 8$$

13. Let $L_1 : \vec{r} = (\hat{i} - \hat{j} + 2\hat{k}) + \lambda(\hat{i} - \hat{j} + 2\hat{k}), \lambda \in \mathbb{R}$
 $L_2 : \vec{r} = (\hat{j} - \hat{k}) + \mu(3\hat{i} + \hat{j} + \hat{k}), \mu \in \mathbb{R}$ and
 $L_3 : \vec{r} = \delta(\ell\hat{i} + m\hat{j} + n\hat{k}), \delta \in \mathbb{R}$

Be three lines such that L_1 is perpendicular to L_2 and L_3 is perpendicular to both L_1 and L_2 . Then the point which lies on L_3 is

- (1) $(-1, 7, 4)$ (2) $(-1, -7, 4)$
 (3) $(1, 7, -4)$ (4) $(1, -7, 4)$

Ans. (1)

Sol. $L_1 \perp L_2$ $L_3 \perp L_1, L_2$

$$3 - 1 + 2P = 0$$

$$P = -1$$

$$\begin{vmatrix} \hat{i} & \hat{j} & \hat{k} \\ 1 & -1 & 2 \\ 3 & 1 & -1 \end{vmatrix} = -\hat{i} + 7\hat{j} + 4\hat{k}$$

$\therefore (-\delta, 7\delta, 4\delta)$ will lie on L_3

For $\delta = 1$ the point will be $(-1, 7, 4)$

14. Let a and b be real constants such that the function f defined by $f(x) = \begin{cases} x^2 + 3x + a, & x \leq 1 \\ bx + 2, & x > 1 \end{cases}$ be

differentiable on \mathbb{R} . Then, the value of $\int_{-2}^2 f(x) dx$

equals

- (1) $\frac{15}{6}$ (2) $\frac{19}{6}$
 (3) 21 (4) 17

Ans. (4)

Sol. f is continuous $f'(x) = 2x + 3, x < 1$

$$\therefore 4 + a = b + 2 \qquad b, x > 1$$

$$a = b - 2 \qquad f \text{ is differentiable}$$

$$\therefore b = 5$$

$$\therefore a = 3$$

$$\begin{aligned} & \int_{-2}^1 (x^2 + 3x + 3) dx + \int_1^2 (5x + 2) dx \\ &= \left[\frac{x^3}{3} + \frac{3x^2}{2} + 3x \right]_{-2}^1 + \left[\frac{5x^2}{2} + 2x \right]_1^2 \\ &= \left(\frac{1}{3} + \frac{3}{2} + 3 \right) - \left(\frac{-8}{3} + 6 - 6 \right) + \left(10 + 4 - \frac{5}{2} - 2 \right) \\ &= 6 + \frac{1}{2} + 12 - \frac{5}{2} = 17 \end{aligned}$$

15. Let $f : \mathbb{R} - \{0\} \rightarrow \mathbb{R}$ be a function satisfying

$$f\left(\frac{x}{y}\right) = \frac{f(x)}{f(y)} \text{ for all } x, y, f(y) \neq 0. \text{ If } f'(1) = 2024,$$

then

- (1) $xf'(x) - 2024f(x) = 0$
 (2) $xf'(x) + 2024f(x) = 0$
 (3) $xf'(x) + f(x) = 2024$
 (4) $xf'(x) - 2023f(x) = 0$

Ans. (1)

Sol. $f\left(\frac{x}{y}\right) = \frac{f(x)}{f(y)}$ $f'(1) = 2024$
 $f(1) = 1$

Partially differentiating w. r. t. x

$$f\left(\frac{x}{y}\right) \cdot \frac{1}{y} = \frac{1}{f(y)} f'(x)$$

$y \rightarrow x$

$$f'(1) \cdot \frac{1}{x} = \frac{f'(x)}{f(x)}$$

$$2024f(x) = xf'(x) \Rightarrow xf'(x) - 2024f(x) = 0$$

16. If z is a complex number, then the number of common roots of the equation $z^{1985} + z^{100} + 1 = 0$ and

$z^3 + 2z^2 + 2z + 1 = 0$, is equal to :

- (1) 1 (2) 2
 (3) 0 (4) 3

Ans. (2)

Sol. $z^{1985} + z^{100} + 1 = 0$ & $z^3 + 2z^2 + 2z + 1 = 0$

$$(z + 1)(z^2 - z + 1) + 2z(z + 1) = 0$$

$$(z + 1)(z^2 + z + 1) = 0$$

$$\Rightarrow z = -1, z = w, w^2$$

Now putting $z = -1$ not satisfy

Now put $z = w$

$$\Rightarrow w^{1985} + w^{100} + 1$$

$$\Rightarrow w^2 + w + 1 = 0$$

Also, $z = w^2$

$$\Rightarrow w^{3970} + w^{200} + 1$$

$$\Rightarrow w + w^2 + 1 = 0$$

Two common root

17. Suppose $2 - p, p, 2 - \alpha, \alpha$ are the coefficient of four consecutive terms in the expansion of $(1+x)^n$. Then the value of $p^2 - \alpha^2 + 6\alpha + 2p$ equals
- (1) 4 (2) 10
(3) 8 (4) 6

Ans. (Bonus)

Sol. $2 - p, p, 2 - \alpha, \alpha$
Binomial coefficients are ${}^nC_r, {}^nC_{r+1}, {}^nC_{r+2}, {}^nC_{r+3}$ respectively

$\Rightarrow {}^nC_r + {}^nC_{r+1} = 2$
 $\Rightarrow {}^{n+1}C_{r+1} = 2 \dots\dots(1)$
Also, ${}^nC_{r+2} + {}^nC_{r+3} = 2$
 $\Rightarrow {}^{n+1}C_{r+3} = 2 \dots\dots(2)$
From (1) and (2)
 ${}^{n+1}C_{r+1} = {}^{n+1}C_{r+3}$
 $\Rightarrow 2r + 4 = n + 1$
 $n = 2r + 3$
 ${}^{2r+4}C_{r+1} = 2$

Data Inconsistent

18. If the domain of the function $f(x) = \log_e \left(\frac{2x+3}{4x^2+x-3} \right) + \cos^{-1} \left(\frac{2x-1}{x+2} \right)$ is $(\alpha, \beta]$, then the value of $5\beta - 4\alpha$ is equal to
- (1) 10 (2) 12
(3) 11 (4) 9

Ans. (2)

Sol. $\frac{2x+3}{4x^2+x-3} > 0$ and $-1 \leq \frac{2x-1}{x+2} \leq 1$

$\frac{2x+3}{(4x-3)(x+1)} > 0$ $\frac{3x+1}{x+2} \geq 0$ & $\frac{x-3}{x+2} \leq 0$

$\frac{-}{-3/2} \frac{+}{-1} \frac{-}{3/4} \frac{+}{}$

$(-\infty, -2) \cup \left[\frac{-1}{3}, \infty \right) \dots\dots(1)$
 $(-2, 3] \dots\dots(2)$
 $\left[\frac{-1}{3}, 3 \right] \dots\dots(3) \quad (1) \cap (2) \cap (3)$
 $\left[\frac{3}{4}, 3 \right]$
 $\alpha = \frac{3}{4} \quad \beta = 3$
 $5\beta - 4\alpha = 15 - 3 = 12$

19. Let $f : \mathbb{R} \rightarrow \mathbb{R}$ be a function defined $f(x) = \frac{x}{(1+x^4)^{1/4}}$ and $g(x) = f(f(f(f(x))))$ then
- $18 \int_0^{\sqrt{2\sqrt{5}}} x^2 g(x) dx$
- (1) 33 (2) 36
(3) 42 (4) 39

Ans. (4)

Sol. $f(x) = \frac{x}{(1+x^4)^{1/4}}$

$f \circ f(x) = \frac{f(x)}{(1+f(x)^4)^{1/4}} = \frac{\frac{x}{(1+x^4)^{1/4}}}{\left(1 + \frac{x^4}{1+x^4}\right)^{1/4}} = \frac{x}{(1+2x^4)^{1/4}}$

$f(f(f(f(x)))) = \frac{x}{(1+4x^4)^{1/4}}$

$18 \int_0^{\sqrt{2\sqrt{5}}} \frac{x^3}{(1+4x^4)^{1/4}} dx$

Let $1 + 4x^4 = t^4$
 $16x^3 dx = 4t^3 dt$
 $\frac{18}{4} \int_1^3 \frac{t^3 dt}{t}$

$= \frac{9}{2} \left(\frac{t^3}{3} \right)_1^3$
 $= \frac{3}{2} [26] = 39$

20. Let $R = \begin{pmatrix} x & & \\ 0 & y & 0 \\ 0 & 0 & z \end{pmatrix}$ be a non-zero 3×3 matrix, where $x \sin \theta = y \sin \left(\theta + \frac{2\pi}{3} \right) = z \sin \left(\theta + \frac{4\pi}{3} \right) \neq 0, \theta \in (0, 2\pi)$. For a square matrix M , let trace (M) denote the sum of all the diagonal entries of M . Then, among the statements:
- (I) Trace $(R) = 0$
(II) If trace $(\text{adj}(\text{adj}(R))) = 0$, then R has exactly one non-zero entry.
- (1) Both (I) and (II) are true
(2) Neither (I) nor (II) is true
(3) Only (II) is true
(4) Only (I) is true

Ans. (3)

Sol. $x \sin \theta = y \sin \left(\theta + \frac{2\pi}{3} \right) = z \sin \left(\theta + \frac{4\pi}{3} \right) = \lambda$ (say), $\lambda \neq 0$

$\Rightarrow x, y, z \neq 0$ and $\sin \theta, \sin \left(\theta + \frac{2\pi}{3} \right), \sin \left(\theta + \frac{4\pi}{3} \right) \neq 0$

Also,

$\sin \theta + \sin \left(\theta + \frac{2\pi}{3} \right) + \sin \left(\theta + \frac{4\pi}{3} \right) = 0 \quad \forall \theta \in \mathbb{R}$

$\Rightarrow x + y + z = \frac{-\lambda \left(\sin^2 \theta + \sin^2 \left(\theta + \frac{2\pi}{3} \right) + \sin^2 \left(\theta + \frac{4\pi}{3} \right) \right)}{2 \sin \theta \sin \left(\theta + \frac{2\pi}{3} \right) \sin \left(\theta + \frac{4\pi}{3} \right)} \neq 0$

(i) Trace (R) = $x + y + z \neq 0$

\Rightarrow Statement (i) is False

(ii) $\text{Adj}(\text{Adj}(R)) = |R| R$

Trace ($\text{Adj}(\text{Adj}(R))$)

= $xyz(x + y + z) \neq 0$

\Rightarrow Hypothesis of conditional statement (ii) is false

\Rightarrow Conditional statement (ii) is vacuously true !!

SECTION-B

21. Let $Y = Y(X)$ be a curve lying in the first quadrant such that the area enclosed by the line $Y - y = Y'(x)(X - x)$ and the co-ordinate axes, where (x, y) is any point on the curve, is always

$\frac{-y^2}{2Y'(x)} + 1, Y'(x) \neq 0$. If $Y(1) = 1$, then $12Y(2)$

equals _____.

Ans. (20)

Sol. $A = \frac{1}{2} \left(\frac{-y}{Y'(x)} + x \right) (y - xY'/x) = \frac{-y^2}{2Y'(x)} + 1$

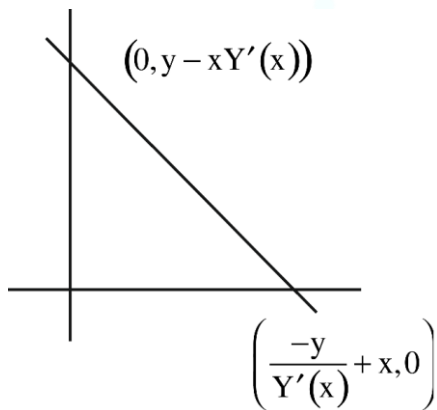

$\Rightarrow (-y + xY'(x))(y - xY'(x)) = -y^2 + 2Y'(x)$

$-y^2 + xyY'(x) + xyY'(x) - x [Y'(x)]^2 = -y^2 + 2Y'(x)$

$2xy - x^2 Y'(x) = 2$

$\frac{dy}{dx} = \frac{2xy - 2}{x^2}$

$\frac{dy}{dx} \cdot \frac{2}{x} y = \frac{-2}{x^2}$

I.F. = $e^{-2 \ln x} = \frac{1}{x^2}$

$y \cdot \frac{1}{x^2} = -\frac{1}{3} x^{-3} + c$

Put $x = 1, y = 1$

$1 = \frac{2}{3} + \Rightarrow c = \frac{1}{3}$

$Y = \frac{2}{3} \cdot \frac{1}{X} + \frac{1}{3} \cdot 2$

$\Rightarrow 12Y(2) = \frac{5}{3} \times 12 = 20$

22. Let a line passing through the point $(-1, 2, 3)$ intersect the lines $L_1 : \frac{x-1}{3} = \frac{y-2}{2} = \frac{z+1}{-2}$ at

$M(\alpha, \beta, \gamma)$ and $L_2 : \frac{x+2}{-3} = \frac{y-2}{-2} = \frac{z-1}{4}$ at $N(a, b,$

$c)$. Then the value of $\frac{(\alpha + \beta + \gamma)^2}{(a + b + c)^2}$ equals _____.

Ans. (196)

Sol. $M(3\lambda + 1, 2\lambda + 2, -2\lambda - 1) \therefore \alpha + \beta + \gamma = 3\lambda + 2$

$N(-3\mu - 2, -2\mu + 2, 4\mu + 1) \therefore a + b + c = -\mu + 1$

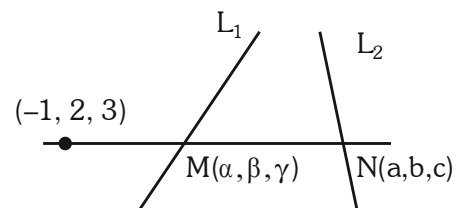

$\frac{3\lambda + 2}{-3\mu - 1} = \frac{2\lambda}{-2\mu} = \frac{-2\lambda - 4}{4\mu - 2}$

$3\lambda\mu + 2\mu = 3\lambda\mu + \lambda$

$2\mu = \lambda$

$2\lambda\mu - \lambda = \lambda\mu + 2\mu$

$\lambda\mu = \lambda + 2\mu$

$\Rightarrow \lambda\mu = 2\lambda$

$$\Rightarrow \mu = 2 \quad (\lambda \neq 0)$$

$$\therefore \lambda = 4$$

$$\alpha + \beta + \gamma = 14$$

$$a + b + c = -1$$

$$\frac{(\alpha + \beta + \gamma)^2}{(a + b + c)^2} = 196$$

23. Consider two circles $C_1 : x^2 + y^2 = 25$ and $C_2 : (x - \alpha)^2 + y^2 = 16$, where $\alpha \in (5, 9)$. Let the angle between the two radii (one to each circle) drawn from one of the intersection points of C_1 and C_2 be $\sin^{-1}\left(\frac{\sqrt{63}}{8}\right)$. If the length of common chord of C_1

and C_2 is β , then the value of $(\alpha\beta)^2$ equals _____.

Ans. (1575)

Sol. $C_1 : x^2 + y^2 = 25$, $C_2 : (x - \alpha)^2 + y^2 = 16$
 $5 < \alpha < 9$

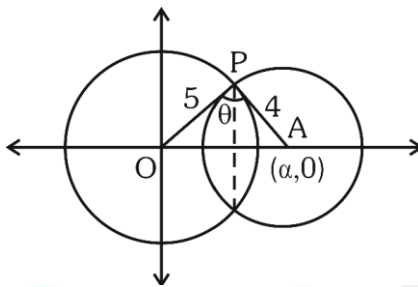

$$\theta = \sin^{-1}\left(\frac{\sqrt{63}}{8}\right)$$

$$\sin \theta = \frac{\sqrt{63}}{8}$$

$$\text{Area of } \triangle OAP = \frac{1}{2} \times \alpha \left(\frac{\beta}{2}\right) = \frac{1}{2} \times 5 \times 4 \sin \theta$$

$$\Rightarrow \alpha\beta = 40 \times \frac{\sqrt{63}}{8}$$

$$\alpha\beta = 5 \times \sqrt{63}$$

$$(\alpha\beta)^2 = 25 \times 63 = 1575$$

24. Let $\alpha = \sum_{k=0}^n \left(\frac{{}^n C_k}{k+1}\right)^2$ and $\beta = \sum_{k=0}^{n-1} \left(\frac{{}^n C_k \cdot C_{k+1}}{k+2}\right)$.

If $5\alpha = 6\beta$, then n equals _____.

Ans. (10)

Sol. $\alpha = \sum_{k=0}^n \frac{{}^n C_k \cdot {}^n C_k}{k+1} \cdot \frac{n+1}{n+1}$
 $= \frac{1}{n+1} \sum_{k=0}^n {}^{n+1} C_{k+1} \cdot {}^n C_{n-k}$

$$\alpha = \frac{1}{n+1} \cdot {}^{2n+1} C_{n+1}$$

$$\beta = \sum_{k=0}^{n-1} {}^n C_k \cdot \frac{{}^n C_{k+1}}{k+2} \cdot \frac{n+1}{n+1}$$

$$\frac{1}{n+1} \sum_{k=0}^{n-1} {}^n C_{n-k} \cdot {}^{n+1} C_{k+2}$$

$$= \frac{1}{n+1} \cdot {}^{2n+1} C_{n+2}$$

$$\frac{\beta}{\alpha} = \frac{{}^{2n+1} C_{n+2}}{{}^{2n+1} C_{n+1}} = \frac{2n+1 - (n+2) + 1}{n+2}$$

$$\frac{\beta}{\alpha} = \frac{n}{n+2} = \frac{5}{6}$$

$$n = 10$$

25. Let S_n be the sum to n-terms of an arithmetic progression 3, 7, 11,

If $40 < \left(\frac{6}{n(n+1)} \sum_{k=1}^n S_k\right) < 42$, then n equals _____.

Ans. (9)

Sol. $S_n = 3 + 7 + 11 + \dots + n$ terms

$$= \frac{n}{2} (6 + (n-1)4) = 3n + 2n^2 - 2n$$

$$= 2n^2 + n$$

$$\sum_{k=1}^n S_k = 2 \sum_{k=1}^n K^2 + \sum_{k=1}^n K$$

$$= 2 \cdot \frac{n(n+1)(2n+1)}{6} + \frac{n(n+1)}{2}$$

$$= n(n+1) \left[\frac{2n+1}{3} + \frac{1}{2} \right]$$

$$= \frac{n(n+1)(4n+5)}{6}$$

$$\Rightarrow 40 < \frac{6}{n(n+1)} \sum_{k=1}^n S_k < 42$$

$$40 < 4n + 5 < 42$$

$$35 < 4n < 37$$

$$n = 9$$

26. In an examination of Mathematics paper, there are 20 questions of equal marks and the question paper is divided into three sections : A, B and C . A student is required to attempt total 15 questions taking at least 4 questions from each section. If section A has 8 questions, section B has 6 questions and section C has 6 questions, then the total number of ways a student can select 15 questions is _____ .

Ans. (11376)

Sol. If 4 questions from each section are selected Remaining 3 questions can be selected either in (1, 1, 1) or (3, 0, 0) or (2, 1, 0)

$$\begin{aligned} \therefore \text{Total ways} &= {}^8C_5 \cdot {}^6C_5 \cdot {}^6C_5 + {}^8C_6 \cdot {}^6C_5 \cdot {}^6C_4 \times 2 + \\ &{}^8C_5 \cdot {}^6C_6 \cdot {}^6C_4 \times 2 + {}^8C_4 \cdot {}^6C_6 \cdot {}^6C_5 \times 2 + {}^8C_7 \cdot {}^6C_4 \cdot {}^6C_4 \\ &= 56 \cdot 6 \cdot 6 + 28 \cdot 6 \cdot 15 \cdot 2 + 56 \cdot 15 \cdot 2 + 70 \cdot 6 \cdot 2 \\ &+ 8 \cdot 15 \cdot 15 \\ &= 2016 + 5040 + 1680 + 840 + 1800 = 11376 \end{aligned}$$

27. The number of symmetric relations defined on the set $\{1, 2, 3, 4\}$ which are not reflexive is _____ .

Ans. (960)

Sol. Total number of relation both symmetric and reflexive = $2^{\frac{n^2-n}{2}}$

$$\text{Total number of symmetric relation} = 2^{\left(\frac{n^2+n}{2}\right)}$$

\Rightarrow Then number of symmetric relation which are not reflexive

$$\begin{aligned} \Rightarrow &2^{\frac{n(n+1)}{2}} - 2^{\frac{n(n-1)}{2}} \\ \Rightarrow &2^{10} - 2^6 \\ \Rightarrow &1024 - 64 \\ &= 960 \end{aligned}$$

28. The number of real solutions of the equation $x(x^2 + 3|x| + 5|x-1| + 6|x-2|) = 0$ is _____ .

Ans. (1)

Sol. $x = 0$ and $x^2 + 3|x| + 5|x-1| + 6|x-2| = 0$

Here all terms are +ve except at $x = 0$

So there is no value of x

Satisfies this equation

Only solution $x = 0$

No of solution 1.

29. The area of the region enclosed by the parabola $(y - 2)^2 = x - 1$, the line $x - 2y + 4 = 0$ and the positive coordinate axes is _____ .

Ans. (5)

Sol. Solving the equations

$$(y - 2)^2 = x - 1 \text{ and } x - 2y + 4 = 0$$

$$X = 2(y - 2)$$

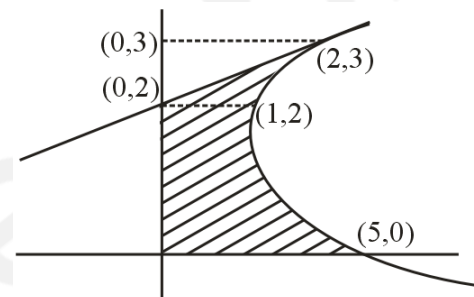

$$\frac{x^2}{4} = x - 1$$

$$x^2 - 4x + 4 = 0$$

$$(x - 2)^2 = 0$$

$$x = 2$$

$$\text{Exclude area (w.r.t. y-axis)} = \int_0^3 x \, dy - \text{Area of } \Delta.$$

$$= \int_0^3 ((y-2)^2 + 1) \, dy - \frac{1}{2} \times 1 \times 2$$

$$= \int_0^3 (y^2 - 4y + 5) \, dy - 1$$

$$= \left[\frac{y^3}{3} - 2y^2 + 5y \right]_0^3 - 1$$

$$= 9 - 18 + 15 - 1 = 5$$

30. The variance σ^2 of the data

x_i	0	1	5	6	10	12	17
f_i	3	2	3	2	6	3	3

Is _____ .

Ans. (29)

Sol.

x_i	f_i	$f_i x_i$	$f_i x_i^2$
0	3	0	0
1	2	2	2
5	3	15	75
6	2	12	72
10	6	60	600
12	3	36	432
17	3	51	867
	$\Sigma f_i = 22$		$\Sigma f_i x_i^2 = 2048$

$$\therefore \Sigma f_i x_i = 176$$

$$\text{So } \bar{x} = \frac{\Sigma f_i x_i}{\Sigma f_i} = \frac{176}{22} = 8$$

$$\begin{aligned} \text{for } \sigma^2 &= \frac{1}{N} \Sigma f_i x_i^2 - (\bar{x})^2 \\ &= \frac{1}{22} \times 2048 - (8)^2 \\ &= 93.090964 \\ &= 29.0909 \end{aligned}$$

(Held On Tuesday 30th January, 2024)

TIME : 3 : 00 PM to 06 : 00 PM

PHYSICS

TEST PAPER WITH SOLUTION

SECTION-A

31. If 50 Vernier divisions are equal to 49 main scale divisions of a travelling microscope and one smallest reading of main scale is 0.5 mm, the Vernier constant of travelling microscope is:

- (1) 0.1 mm
- (2) 0.1 cm
- (3) 0.01 cm
- (4) 0.01 mm

Ans. (4)

Sol. $50V + S = 49S + S$

$$S = 50(S - V)$$

$$.5 = 50(S - V)$$

$$S - V = \frac{0.5}{50} = \frac{1}{100} = 0.01 \text{ mm}$$

32. A block of mass 1 kg is pushed up a surface inclined to horizontal at an angle of 60° by a force of 10 N parallel to the inclined surface as shown in figure. When the block is pushed up by 10 m along inclined surface, the work done against frictional force is : [g = 10 m/s²]

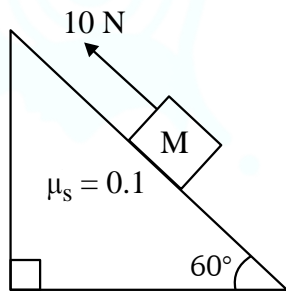

- (1) $5\sqrt{3}$ J
- (2) 5 J
- (3) 5×10^3 J
- (4) 10 J

Ans. (2)

Sol. Work done against frictional force
 $= \mu N \times 10$
 $= 0.1 \times 5 \times 10 = 5 \text{ J}$

33. For the photoelectric effect, the maximum kinetic energy (E_k) of the photoelectrons is plotted against the frequency (ν) of the incident photons as shown in figure. The slope of the graph gives

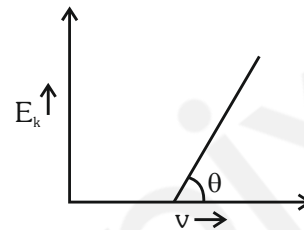

- (1) Ratio of Planck's constant to electric charge
- (2) Work function of the metal
- (3) Charge of electron
- (4) Planck's constant

Ans. (4)

Sol. K.E. = $h\nu - \phi$

$$\tan \theta = h$$

34. A block of ice at -10°C is slowly heated and converted to steam at 100°C . Which of the following curves represent the phenomenon qualitatively:

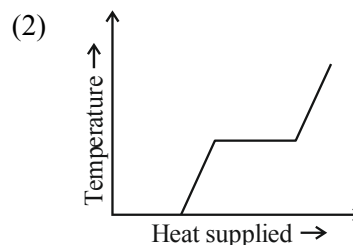
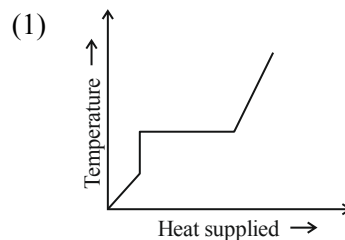

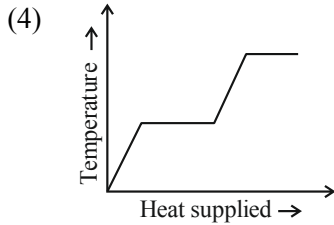
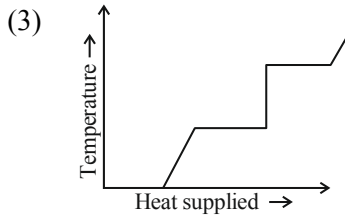

Ans. (4)

35. In a nuclear fission reaction of an isotope of mass M , three similar daughter nuclei of same mass are formed. The speed of a daughter nuclei in terms of mass defect ΔM will be :

- (1) $\sqrt{\frac{2c\Delta M}{M}}$ (2) $\frac{\Delta Mc^2}{3}$
 (3) $c\sqrt{\frac{2\Delta M}{M}}$ (4) $c\sqrt{\frac{3\Delta M}{M}}$

Ans. (3)

Sol. $(X) \rightarrow (Y) + (Z) + (P)$
 $M \quad M/3 \quad M/3 \quad M/3$

$$\Delta Mc^2 = \frac{1}{2} \frac{M}{3} V^2 + \frac{1}{2} \frac{M}{3} V^2 + \frac{1}{2} \frac{M}{3} V^2$$

$$V = c\sqrt{\frac{2\Delta M}{M}}$$

36. Choose the correct statement for processes A & B shown in figure.

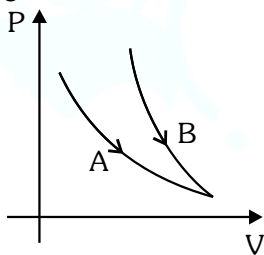

- (1) $PV^\gamma = k$ for process B and $PV = k$ for process A.
 (2) $PV = k$ for process B and A.

(3) $\frac{P^{\gamma-1}}{T^\gamma} = k$ for process B and $T = k$ for process A.

(4) $\frac{T^\gamma}{P^{\gamma-1}} = k$ for process A and $PV = k$ for process B.

Ans. (1 & 3)

Sol. Steeper curve (B) is adiabatic
 Adiabatic $\Rightarrow PV^\gamma = \text{const.}$

Or $P\left(\frac{T}{P}\right)^\gamma = \text{const.}$

$$\frac{T^\gamma}{P^{\gamma-1}} = \text{const.}$$

Curve (A) is isothermal

$$T = \text{const.}$$

$$PV = \text{const.}$$

37. An electron revolving in n^{th} Bohr orbit has magnetic moment μ_n . If $\mu_n \propto n^x$, the value of x is:

- (1) 2 (2) 1
 (3) 3 (4) 0

Ans. (2)

Sol. Magnetic moment $= i\pi r^2$

$$\mu = \frac{evr}{2}$$

$$\mu \propto \left(\frac{1}{n}\right)n^2$$

$$\mu \propto n$$

$$x = 1$$

38. An alternating voltage $V(t) = 220 \sin 100\pi t$ volt is applied to a purely resistive load of 50Ω . The time taken for the current to rise from half of the peak value to the peak value is:

- (1) 5 ms
 (2) 3.3 ms
 (3) 7.2 ms
 (4) 2.2 ms

Ans. (2)

Sol. Rising half to peak

$$t = T/6$$

$$t = \frac{2\pi}{6\omega} = \frac{\pi}{3\omega} = \frac{\pi}{300\pi} = \frac{1}{300} = 3.33 \text{ ms}$$

39. A block of mass m is placed on a surface having vertical cross section given by $y = x^2/4$. If coefficient of friction is 0.5, the maximum height above the ground at which block can be placed without slipping is:

- (1) $1/4$ m (2) $1/2$ m
 (3) $1/6$ m (4) $1/3$ m

Ans. (1)

Sol. $\frac{dy}{dx} = \tan \theta = \frac{x}{2} = \mu = \frac{1}{2}$

$$x = 1, y = 1/4$$

40. If the total energy transferred to a surface in time t is 6.48×10^5 J, then the magnitude of the total momentum delivered to this surface for complete absorption will be :
- (1) 2.46×10^{-3} kg m/s
 - (2) 2.16×10^{-3} kg m/s
 - (3) 1.58×10^{-3} kg m/s
 - (4) 4.32×10^{-3} kg m/s

Ans. (2)

Sol. $p = \frac{E}{C} = \frac{6.48 \times 10^5}{3 \times 10^8} = 2.16 \times 10^{-3}$

41. A beam of unpolarised light of intensity I_0 is passed through a polaroid A and then through another polaroid B which is oriented so that its principal plane makes an angle of 45° relative to that of A. The intensity of emergent light is :
- (1) $I_0/4$
 - (2) I_0
 - (3) $I_0/2$
 - (4) $I_0/8$

Ans. (1)

Sol. Intensity of emergent light
 $= \frac{I_0}{2} \cos^2 45^\circ = \frac{I_0}{4}$

42. Escape velocity of a body from earth is 11.2 km/s. If the radius of a planet be one-third the radius of earth and mass be one-sixth that of earth, the escape velocity from the planet is:
- (1) 11.2 km/s
 - (2) 8.4 km/s
 - (3) 4.2 km/s
 - (4) 7.9 km/s

Ans. (4)

Sol. $R_p = \frac{R_e}{3}, M = \frac{M_e}{6}$

$V_e = \sqrt{\frac{2GM_e}{R_e}} \dots(i)$

$V_p = \sqrt{\frac{2GM_p}{R_p}} \dots(ii)$

$\frac{V_e}{V_p} = \sqrt{2}$

$V_p = \frac{V_e}{\sqrt{2}} = \frac{11.2}{\sqrt{2}} = 7.9 \text{ km/sec}$

43. A particle of charge ' $-q$ ' and mass ' m ' moves in a circle of radius ' r ' around an infinitely long line charge of linear density ' $+\lambda$ '. Then time period will be given as:
 (Consider k as Coulomb's constant)

(1) $T^2 = \frac{4\pi^2}{2k\lambda q}$ (2) $T = 2\pi r \sqrt{\frac{m}{2k\lambda q}}$

(3) $T = \frac{1}{2\pi r} \sqrt{\frac{m}{2k\lambda q}}$ (4) $T = \frac{1}{2\pi} \sqrt{\frac{2k\lambda q}{m}}$

Ans. (2)

Sol. $\frac{2k\lambda q}{r} = m\omega^2 r$

$\omega^2 = \frac{2k\lambda q}{mr^2}$

$\left(\frac{2\pi}{T}\right)^2 = \frac{2k\lambda q}{mr^2}$

$T = 2\pi r \sqrt{\frac{m}{2k\lambda q}}$

44. If mass is written as $m = k c^p G^{-1/2} h^{1/2}$ then the value of P will be : (Constants have their usual meaning with k a dimensionless constant)
- (1) 1/2
 - (2) 1/3
 - (3) 2
 - (4) -1/3

Ans. (1)

Sol. $m = k c^p G^{-1/2} h^{1/2}$

$M^1 L^0 T^0 = [L T^{-1}]^p [M^{-1} L^3 T^{-2}]^{-1/2} [M L^2 T^{-1}]^{1/2}$

By comparing $P = 1/2$

45. In the given circuit, the voltage across load resistance (R_L) is:

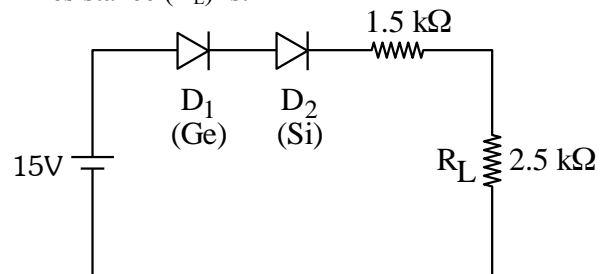

- (1) 8.75 V
- (2) 9.00 V
- (3) 8.50 V
- (4) 14.00 V

Ans. (1)

Sol.

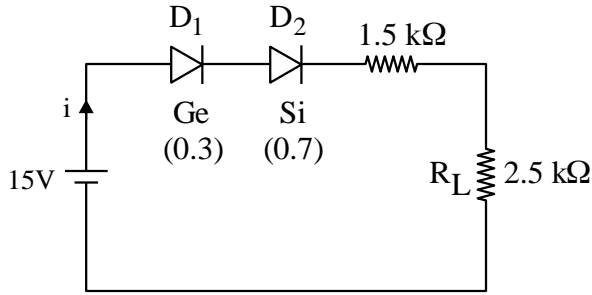

$$i = \frac{14}{4} = 3.5 \text{ mA}$$

$$V_L = iR_L = 3.5 \times 2.5 \text{ volt} = 8.75 \text{ volt}$$

46. If three moles of monoatomic gas $\left(\gamma = \frac{5}{3}\right)$ is mixed with two moles of a diatomic gas $\left(\gamma = \frac{7}{5}\right)$,

the value of adiabatic exponent γ for the mixture is:

- (1) 1.75 (2) 1.40
(3) 1.52 (3) 1.35

Ans. (3)

Sol. $f_1 = 3, \quad f_2 = 5$
 $n_1 = 3, \quad n_2 = 2$

$$f_{\text{mixture}} = \frac{n_1 f_1 + n_2 f_2}{n_1 + n_2} = \frac{9 + 10}{5} = \frac{19}{5}$$

$$\gamma_{\text{mixture}} = 1 + \frac{2 \times 5}{19} = \frac{29}{19} = 1.52$$

47. Three blocks A, B and C are pulled on a horizontal smooth surface by a force of 80 N as shown in figure

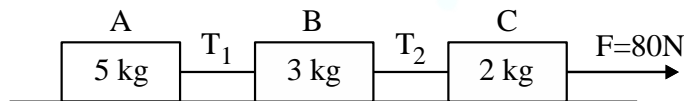

The tensions T_1 and T_2 in the string are respectively:

- (1) 40N, 64N
(2) 60N, 80N
(3) 88N, 96N
(4) 80N, 100N

Ans. (1)

Sol. $a_A = a_B = a_C = \frac{F}{5 + 3 + 2} = \frac{80}{10} = 8 \text{ m/s}^2$

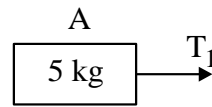

$$T_1 = 5 \times 8 = 40$$

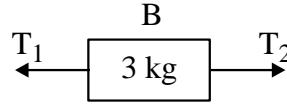

$$T_2 - T_1 = 3 \times 8 \Rightarrow T_2 = 64$$

48. When a potential difference V is applied across a wire of resistance R , it dissipates energy at a rate W . If the wire is cut into two halves and these halves are connected mutually parallel across the same supply, the energy dissipation rate will become:

- (1) $1/4W$ (2) $1/2W$
(3) $2W$ (4) $4W$

Ans. (4)

Sol. $\frac{v^2}{R} = W \quad \dots(i)$

$$\frac{v^2}{\frac{R}{2}} = W' \quad \dots(ii)$$

From (i) & (ii), we get
 $W' = 4W$

49. Match List I with List II

List-I		List-II	
A.	Gauss's law of magnetostatics	I.	$\oint \vec{E} \cdot \vec{da} = \frac{1}{\epsilon_0} \rho dV$
B.	Faraday's law of electro magnetic induction	II.	$\oint \vec{B} \cdot \vec{da} = -0$
C.	Ampere's law	III.	$\oint \vec{E} \cdot \vec{dl} = \frac{-d}{dt} \int \vec{B} \cdot \vec{da}$
D.	Gauss's law of electrostatics	IV.	$\oint \vec{B} \cdot \vec{dl} = -\mu_0 I$

Choose the correct answer from the options given below:

- (1) A-I, B-III, C-IV, D-II
(2) A-III, B-IV, C-I, D-II
(3) A-IV, B-II, C-III, D-I
(4) A-II, B-III, C-IV, D-I

Ans. (4)

Sol. Maxwell's equation

50. Projectiles A and B are thrown at angles of 45° and 60° with vertical respectively from top of a 400 m high tower. If their ranges and times of flight are same, the ratio of their speeds of projection $v_A : v_B$ is :

- (1) $1 : \sqrt{3}$ (2) $\sqrt{2} : 1$
 (3) $1 : 2$ (4) $1 : \sqrt{2}$

Ans. (Bonus)

Sol.

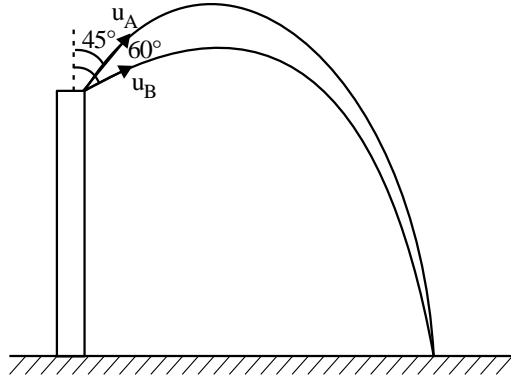

For u_A & u_B time of flight and range can not be same. So above options are incorrect.

SECTION-B

51. A power transmission line feeds input power at 2.3 kV to a step down transformer with its primary winding having 3000 turns. The output power is delivered at 230 V by the transformer. The current in the primary of the transformer is 5A and its efficiency is 90%. The winding of transformer is made of copper. The output current of transformer is _____ A.

Ans. (45)

Sol. $P_1 = 2300 \times 5$ watt

$$P_0 = 2300 \times 5 \times 0.9 = 230 \times I_2$$

$$I_2 = 45A$$

52. A big drop is formed by coalescing 1000 small identical drops of water. If E_1 be the total surface energy of 1000 small drops of water and E_2 be the surface energy of single big drop of water, the $E_1 : E_2$ is $x : 1$ where $x =$ _____.

Ans. (10)

Sol. $\rho \left(\frac{4}{3} \pi r^3 \right) 1000 = 4 \pi R^3 \rho$

$$R = 10r$$

$$E_1 = 1000 \times 4 \pi r^2 \times S$$

$$E_2 = 4 \pi (10r)^2 S$$

$$\frac{E_1}{E_2} = \frac{10}{x}, \quad x = 10$$

53. Two discs of moment of inertia $I_1 = 4 \text{ kg m}^2$ and $I_2 = 2 \text{ kg m}^2$ about their central axes & normal to their planes, rotating with angular speeds 10 rad/s & 4 rad/s respectively are brought into contact face to face with their axis of rotation coincident. The loss in kinetic energy of the system in the process is _____ J.

Ans. (24)

Sol. $I_1 \omega_1 + I_2 \omega_2 = (I_1 + I_2) \omega_0$ (C.O.A.M.)

$$\text{gives } \omega_0 = 8 \text{ rad/s}$$

$$E_1 = \frac{1}{2} I_1 \omega_1^2 + \frac{1}{2} I_2 \omega_2^2 = 216 \text{ J}$$

$$E_2 = \frac{1}{2} (I_1 + I_2) \omega_0^2 = 192 \text{ J}$$

$$\therefore \Delta E = 24 \text{ J}$$

54. In an experiment to measure the focal length (f) of a convex lens, the magnitude of object distance (x) and the image distance (y) are measured with reference to the focal point of the lens. The y-x plot is shown in figure.

The focal length of the lens is _____ cm.

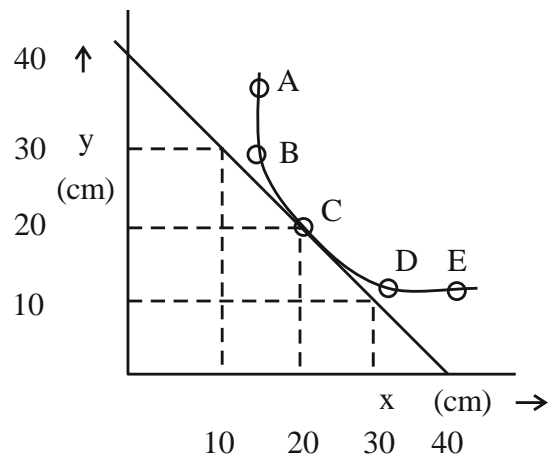

Ans. (20)

Sol. $\frac{1}{f + 20} - \frac{1}{-(f + 20)} = \frac{1}{f}$

$$\frac{2}{f + 20} = \frac{1}{f} \quad f = 20 \text{ cm}$$

$$\text{Or } x_1 x_2 = f^2 \text{ gives } f = 20 \text{ cm}$$

55. A vector has magnitude same as that of $\vec{A} = 3\hat{i} + 4\hat{j}$ and is parallel to $\vec{B} = 4\hat{i} + 3\hat{j}$. The x and y components of this vector in first quadrant are x and 3 respectively where x = _____.

Ans. (4)

Sol. $\vec{N} = |\vec{A}| \hat{B} = \frac{5(4\hat{i} + 3\hat{j})}{5} = 4\hat{i} + 3\hat{j}$

$\therefore x = 4$

56. The current of 5A flows in a square loop of sides 1 m is placed in air. The magnetic field at the centre of the loop is $X\sqrt{2} \times 10^{-7} \text{ T}$. The value of X is _____.

Ans. (40)

Sol. $B = 4 \times \frac{\mu_0 i}{4\pi(\frac{1}{2})} \left(\frac{1}{\sqrt{2}} + \sqrt{\quad} \right)$
 $= 4 \times 10^{-7} \times 5 \times 2 \times \sqrt{2}$
 $= 40\sqrt{2} \times 10^{-7} \text{ T}$

57. Two identical charged spheres are suspended by string of equal lengths. The string make an angle of 37° with each other. When suspended in a liquid of density 0.7 g/cm^3 , the angle remains same. If density of material of the sphere is 1.4 g/cm^3 , the dielectric constant of the liquid is _____

$\left(\tan 37^\circ = \frac{3}{4} \right)$

Ans. (2)

Sol.

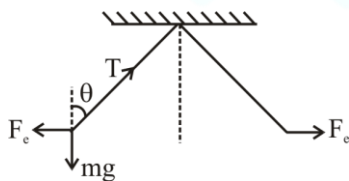

$T \cos \theta = mg$

$T \sin \theta = F_e$

$\tan \theta = \frac{F_e}{mg}$

$\tan \theta = \frac{F_e}{\rho_B V g} \quad \dots(i)$

$\tan \theta = \frac{F_e}{\frac{k}{(\rho - \rho_L) V g}} \quad \dots(ii)$

From Eq. (i) & (ii)

$\rho_B V g = (\rho_B - \rho_L) k V g$

$1.4 = 0.7 k$

$k = 2$

58. A simple pendulum is placed at a place where its distance from the earth's surface is equal to the radius of the earth. If the length of the string is 4m, then the time period of small oscillations will be _____ s. [take $g = \pi^2 \text{ ms}^{-2}$]

Ans. (8)

Sol. Acceleration due to gravity $g' = \frac{g}{4}$

$T = 2 \sqrt{\frac{4\ell}{g}}$

$T = 2 \sqrt{\frac{4 \times \quad}{g}}$

$T = 2\pi \frac{4}{\pi} = 8 \text{ s}$

59. A point source is emitting sound waves of intensity $16 \times 10^{-8} \text{ Wm}^{-2}$ at the origin. The difference in intensity (magnitude only) at two points located at a distances of 2m and 4m from the origin respectively will be _____ $\times 10^{-8} \text{ Wm}^{-2}$.

Ans. (Bonus)

Sol. Question is wrong as data is incomplete.

60. Two resistance of $100\ \Omega$ and $200\ \Omega$ are connected in series with a battery of $4\ \text{V}$ and negligible internal resistance. A voltmeter is used to measure voltage across $100\ \Omega$ resistance, which gives reading as $1\ \text{V}$. The resistance of voltmeter must be _____ Ω .

Ans. (200)

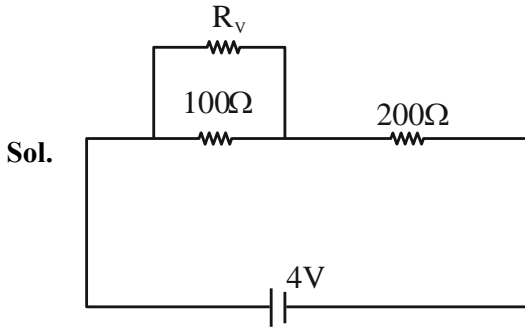

$$\frac{R_v \cdot 100}{R_v + 100} = \frac{200}{3}$$

$$3R_v = 2R_v + 200$$

$$R_v = 200$$

(Held On Tuesday 30th January, 2024)
TIME : 3 : 00 PM to 6 : 00 PM
CHEMISTRY
SECTION-A

61. Which among the following purification methods is based on the principle of "Solubility" in two different solvents?

- (1) Column Chromatography
- (2) Sublimation
- (3) Distillation
- (4) Differential Extraction

Ans. (4)

Sol. Different Extraction

Different layers are formed which can be separated in funnel. (Theory based).

62. Salicylaldehyde is synthesized from phenol, when reacted with

- (1) HCOCl , NaOH
- (2) CO_2 , NaOH
- (3) CCl_4 , NaOH
- (4) HCCl_3 , NaOH

Ans. (4)

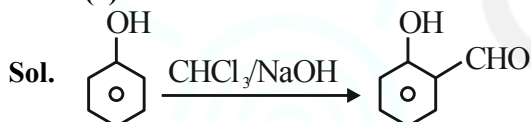

63. Given below are two statements:

Statement – I: High concentration of strong nucleophilic reagent with secondary alkyl halides which do not have bulky substituents will follow $\text{S}_{\text{N}}2$ mechanism.

Statement – II: A secondary alkyl halide when treated with a large excess of ethanol follows $\text{S}_{\text{N}}1$ mechanism.

In the light of the above statements, choose the most appropriate from the questions given below:

- (1) Statement I is true but Statement II is false.
- (2) Statement I is false but Statement II is true.
- (3) Both statement I and Statement II are false.
- (4) Both statement I and Statement II are true.

Ans. (4)

TEST PAPER WITH SOLUTION

Sol. **Statement – I:** Rate of $\text{S}_{\text{N}}2 \propto [\text{R-X}][\text{Nu}^-]$

$\text{S}_{\text{N}}2$ reaction is favoured by high concentration of nucleophile (Nu^-) & less crowding in the substrate molecule.

Statement – II: Solvolysis follows $\text{S}_{\text{N}}1$ path.

Both are correct Statements.

64. m-chlorobenzaldehyde on treatment with 50% KOH solution yields

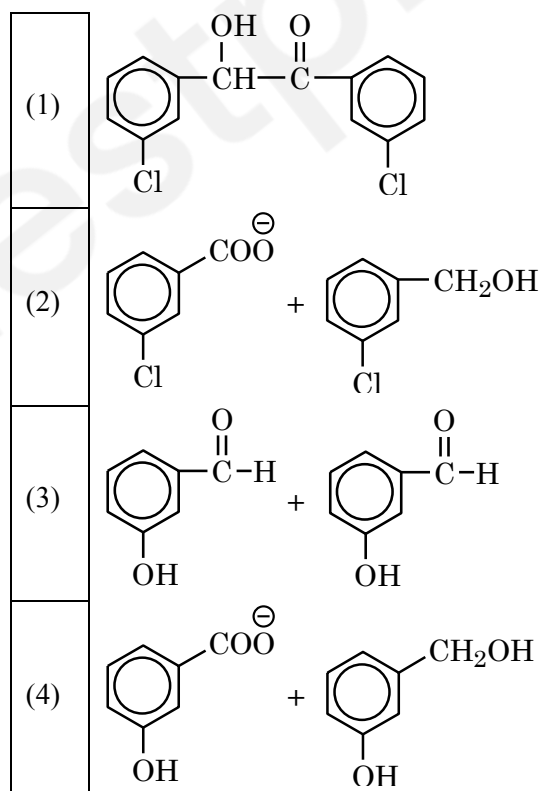

Ans. (2)

Sol. Meta-chlorobenzaldehyde will undergo

Cannizzaro reaction with 50% KOH to give m-chlorobenzoate ion and m-chlorobenzyl alcohol.

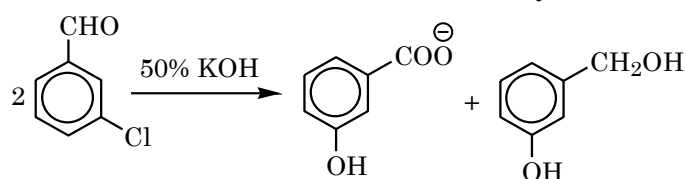

65. Given below are two statements: One is labelled as Assertion A and the other is labelled as Reason R.

Assertion A : H_2Te is more acidic than H_2S .

Reason R: Bond dissociation enthalpy of H_2Te is lower than H_2S .

In the light of the above statements. Choose the most appropriate from the options given below.

- (1) Both A and R are true but R is NOT the correct explanation of A.
- (2) Both A and R are true and R is the correct explanation of A.
- (3) A is false but R is true.
- (4) A is true but R is false.

Ans. (2)

Sol. Due to lower Bond dissociation enthalpy of H_2Te it ionizes to give H^+ more easily than H_2S .

66. Product A and B formed in the following set of reactions are:

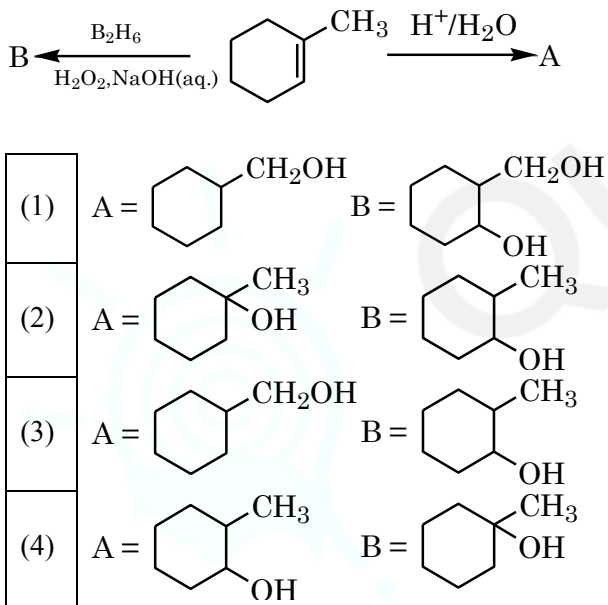

Ans. (2)

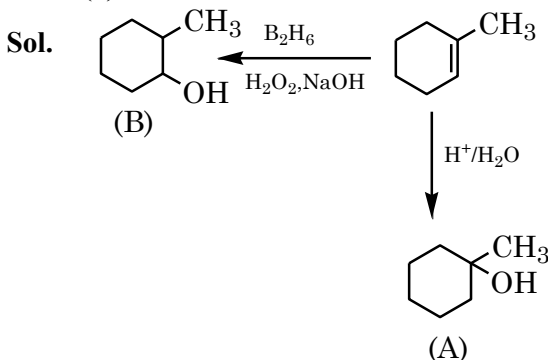

67. IUPAC name of following compound is

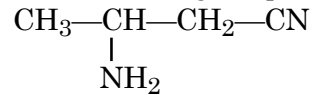

- (1) 2-Aminopentanitrile
- (2) 2-Aminobutanenitrile
- (3) 3-Aminobutanenitrile
- (4) 3-Aminopropanenitrile

Ans. (3)

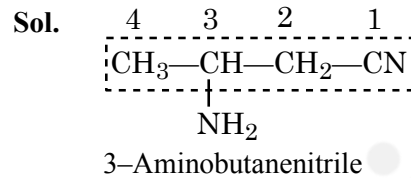

68. The products A and B formed in the following reaction scheme are respectively

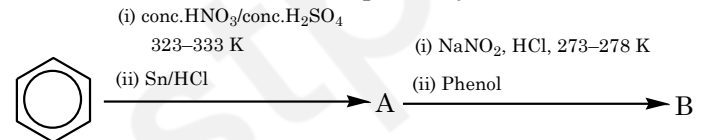

- | | |
|-----|--|
| (1) | |
| (2) | |
| (3) | |
| (4) | |

Ans. (3)

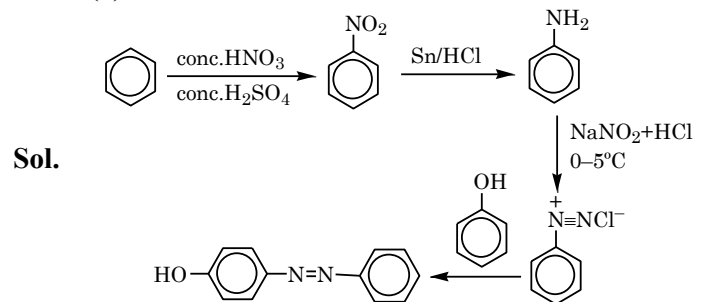

69. The molecule/ion with square pyramidal shape is:

- (1) $[\text{Ni}(\text{CN})_4]^{2-}$ (2) PCl_5
 (3) BrF_5 (4) PF_5

Ans. (3)

Sol. BrF_5

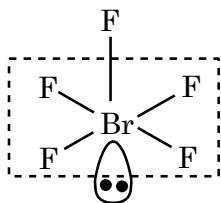

Square Pyramidal.

70. The orange colour of $\text{K}_2\text{Cr}_2\text{O}_7$ and purple colour of KMnO_4 is due to

- (1) Charge transfer transition in both.
 (2) $d \rightarrow d$ transition in KMnO_4 and charge transfer transitions in $\text{K}_2\text{Cr}_2\text{O}_7$.
 (3) $d \rightarrow d$ transition in $\text{K}_2\text{Cr}_2\text{O}_7$ and charge transfer transitions in KMnO_4 .
 (4) $d \rightarrow d$ transition in both.

Ans. (1)

Sol. $\left. \begin{array}{l} \text{K}_2\text{Cr}_2\text{O}_7 \rightarrow \text{Cr}^{+6} \rightarrow \text{No } d-d \text{ transition} \\ \text{KMnO}_4 \rightarrow \text{Mn}^{7+} \rightarrow \text{No } d-d \text{ transition} \end{array} \right\} \text{Charge transfer}$

71. Alkaline oxidative fusion of MnO_2 gives "A" which on electrolytic oxidation in alkaline solution produces B. A and B respectively are:

- (1) Mn_2O_7 and MnO_4^-
 (2) MnO_4^{2-} and MnO_4^-
 (3) Mn_2O_3 and MnO_4^{2-}
 (4) MnO_4^{2-} and Mn_2O_7

Ans. (2)

Sol. Alkaline oxidative fusion of MnO_2 :

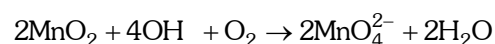

Electrolytic oxidation of MnO_4^{2-} in alkaline medium.

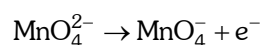

72. If a substance 'A' dissolves in solution of a mixture of 'B' and 'C' with their respective number of moles as n_A , n_B and n_C , mole fraction of C in the solution is:

- (1) $\frac{n_C}{n_A \times n_B \times n_C}$ (2) $\frac{n_C}{n_A + n_B + n_C}$
 (3) $\frac{n_C}{n_A - n_B - n_C}$ (4) $\frac{n_B}{n_A + n_B}$

Ans. (2)

Sol. Mole fraction of C = $\frac{n_C}{n_A + n_B + n_C}$

73. Given below are two statements:

Statement – I: Along the period, the chemical reactivity of the element gradually increases from group 1 to group 18.

Statement – II: The nature of oxides formed by group 1 element is basic while that of group 17 elements is acidic.

In the light above statements, choose the most appropriate from the questions given below:

- (1) Both statement I and Statement II are true.
 (2) Statement I is true but Statement II is False.
 (3) Statement I is false but Statement II is true.
 (4) Both Statement I and Statement II is false.

Ans. (3)

Sol. Chemical reactivity of elements decreases along the period therefore statement – I is false.

Group – 1 elements form basic nature oxides while group – 17 elements form acidic oxides therefore statement – II is true.

74. The coordination geometry around the manganese in decacarbonyldimanganese(0)

- (1) Octahedral (2) Trigonal bipyramidal
 (3) Square pyramidal (4) Square planar

Ans. (1)

Sol. $\text{Mn}_2(\text{CO})_{10}$

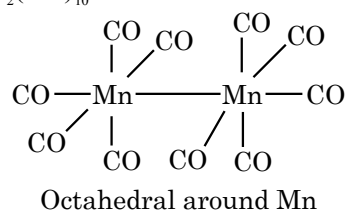

75. Given below are two statements:

Statement-I: Since fluorine is more electronegative than nitrogen, the net dipole moment of NF_3 is greater than NH_3 .

Statement-II: In NH_3 , the orbital dipole due to lone pair and the dipole moment of NH bonds are in opposite direction, but in NF_3 the orbital dipole due to lone pair and dipole moments of N-F bonds are in same direction.

In the light of the above statements. Choose the most appropriate from the options given below.

- (1) Statement I is true but Statement II is false.
- (2) Both Statement I and Statement II are false.
- (3) Both statement I and Statement II is are true.
- (4) Statement I is false but Statement II is are true.

Ans. (2)

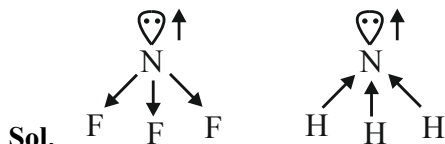

76. The correct stability order of carbocations is

- (1) $(\text{CH}_3)_3\text{C}^+ > \text{CH}_3-\overset{+}{\text{C}}\text{H}_2 > (\text{CH}_3)_2\overset{+}{\text{C}}\text{H} > \overset{+}{\text{C}}\text{H}_3$
- (2) $\overset{+}{\text{C}}\text{H}_3 > (\text{CH}_3)_2\overset{+}{\text{C}}\text{H} > \text{CH}_3-\overset{+}{\text{C}}\text{H}_2 > (\text{CH}_3)_3\overset{+}{\text{C}}$
- (3) $(\text{CH}_3)_3\overset{+}{\text{C}} > (\text{CH}_3)_2\overset{+}{\text{C}}\text{H} > \text{CH}_3-\overset{+}{\text{C}}\text{H}_2 > \overset{+}{\text{C}}\text{H}_3$
- (4) $\overset{+}{\text{C}}\text{H}_3 > \text{CH}_3-\overset{+}{\text{C}}\text{H}_2 > \text{CH}_3-\overset{+}{\text{C}}\text{H} > (\text{CH}_3)_3\overset{+}{\text{C}}$

|

CH_3

Ans. (3)

Sol. More no. of hyperconjugable Hydrogens, more stable is the carbocations.

77. The solution from the following with highest depression in freezing point/lowest freezing point is

- (1) 180 g of acetic acid dissolved in water
- (2) 180 g of acetic acid dissolved in benzene
- (3) 180 g of benzoic acid dissolved in benzene
- (4) 180 g of glucose dissolved in water

Ans. (1)

Sol. ΔT_f is maximum when $i \times m$ is maximum.

$$1) \quad m_1 = \frac{180}{60}, \quad i = 1 + \alpha$$

Hence

$$\Delta T_f = (1 + \alpha) \cdot k_f = 3 \times 1.86 = 5.58^\circ\text{C} \quad (\alpha \ll 1)$$

$$2) \quad m_2 = \frac{180}{60} = 3, \quad i = 0.5, \quad \Delta T_f = \frac{3}{2} \times k_f' = 7.68^\circ\text{C}$$

$$3) \quad m_3 = \frac{180}{122} = 1.48, \quad i = 0.5, \quad \Delta T_f = \frac{1.48}{2} \times k_f' = 3.8^\circ\text{C}$$

$$4) \quad m_4 = \frac{180}{180} = 1, \quad i = 1, \quad \Delta T_f = 1 \cdot k_f' = 1.86^\circ\text{C}$$

As per NCERT, $k_f'(\text{H}_2\text{O}) = 1.86 \text{ k} \cdot \text{kg mol}^{-1}$

$$k_f'(\text{Benzene}) = 5.12 \text{ k} \cdot \text{kg mol}^{-1}$$

78. A and B formed in the following reactions are:

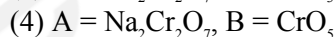
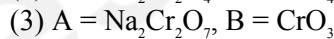
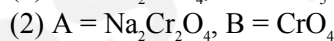
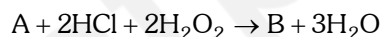
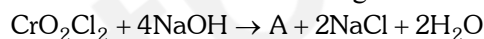

Ans. (1)

Sol. $\text{CrO}_2\text{Cl}_2 + 4\text{NaOH} \rightarrow \text{Na}_2\text{CrO}_4 + 2\text{NaCl} + 2\text{H}_2\text{O}$
(A)

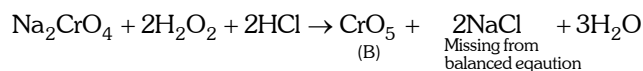

79. Choose the correct statements about the hydrides of group 15 elements.

A. The stability of the hydrides decreases in the order $\text{NH}_3 > \text{PH}_3 > \text{AsH}_3 > \text{SbH}_3 > \text{BiH}_3$

B. The reducing ability of the hydrides increases in the order $\text{NH}_3 < \text{PH}_3 < \text{AsH}_3 < \text{SbH}_3 < \text{BiH}_3$

C. Among the hydrides, NH_3 is strong reducing agent while BiH_3 is mild reducing agent.

D. The basicity of the hydrides increases in the order $\text{NH}_3 < \text{PH}_3 < \text{AsH}_3 < \text{SbH}_3 < \text{BiH}_3$

Choose the most appropriate from the option given below:

(1) B and C only (2) C and D only

(3) A and B only (4) A and D only

Ans. (3)

Sol. On moving down the group, bond strength of M-H bond decreases, which reduces the thermal stability but increases reducing nature of hydrides, hence A and B are correct statements.

80. Reduction potential of ions are given below:

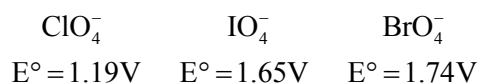

The correct order of their oxidising power is:

- (1) $\text{ClO}_4^- > \text{IO}_4^- > \text{BrO}_4^-$
- (2) $\text{BrO}_4^- > \text{IO}_4^- > \text{ClO}_4^-$
- (3) $\text{BrO}_4^- > \text{ClO}_4^- > \text{IO}_4^-$
- (4) $\text{IO}_4^- > \text{BrO}_4^- > \text{ClO}_4^-$

Ans. (2)

Sol. Higher the value of \oplus ve SRP (Std. reduction potential) more is tendency to undergo reduction, so better is oxidising power of reactant.

Hence, ox. Power:- $\text{BrO}_4^- > \text{IO}_4^- > \text{ClO}_4^-$

SECTION-B

81. Number of complexes which show optical isomerism among the following is _____.

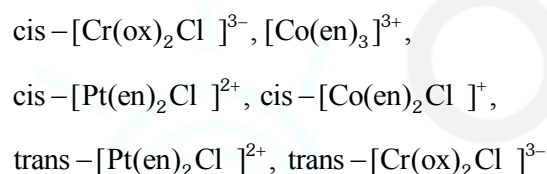

Ans. (4)

Sol. $\text{cis} - [\text{Cr}(\text{ox})_2\text{Cl}]^{3-} \rightarrow$ can show optical isomerism (no POS & COS)

$[\text{Co}(\text{en})_3]^{3+} \rightarrow$ can show (no POS & COS)

$\text{cis} - [\text{Pt}(\text{en})_2\text{Cl}]^{2+} \rightarrow$ can show (no POS & COS)

$\text{cis} - [\text{Co}(\text{en})_2\text{Cl}]^+ \rightarrow$ can show (no POS & COS)

$\text{trans} - [\text{Pt}(\text{en})_2\text{Cl}]^{2+} \rightarrow$ can't show (contains POS & COS)

$\text{trans} - [\text{Cr}(\text{ox})_2\text{Cl}]^{3-} \rightarrow$ can't show (contains POS & COS)

82. NO_2 required for a reaction is produced by decomposition of N_2O_5 in CCl_4 as by equation

$$2\text{N}_2\text{O}_{5(g)} \rightarrow \text{NO}_{2(g)} + \text{O}_{2(g)}$$

The initial concentration of N_2O_5 is 3 mol L^{-1} and it is 2.75 mol L^{-1} after 30 minutes.

The rate of formation of NO_2 is $x \times 10^{-3} \text{ mol L}^{-1} \text{ min}^{-1}$, value of x is _____.

Ans. (17)

Sol. Rate of reaction (ROR)

$$= -\frac{1}{2} \frac{\Delta[\text{N}_2\text{O}_5]}{\Delta t} = -\frac{[\text{NO}_2]}{\Delta t} = \frac{[\text{O}_2]}{\Delta t}$$

$$\text{ROR} = -\frac{1}{2} \frac{\Delta[\text{N}_2\text{O}_5]}{\Delta t} = -\frac{1}{2} \frac{(2.75 - 3)}{30} \text{ mol L}^{-1} \text{ min}^{-1}$$

$$\text{ROR} = -\frac{1}{2} \frac{(-0.25)}{30} \text{ mol L}^{-1} \text{ min}^{-1}$$

$$\text{ROR} = \frac{1}{240} \text{ mol L}^{-1} \text{ min}^{-1}$$

$$\text{Rate of formation of } \text{NO}_2 = \frac{\Delta[\text{NO}_2]}{\Delta t} = 4 \times \text{ROR}$$

$$= \frac{4}{240} = 16.66 \times 10^{-3} \text{ mol L}^{-1} \text{ min}^{-1} \approx 17 \times 10^{-3}$$

83. Two reactions are given below:

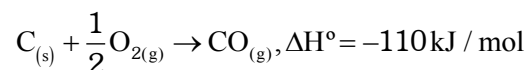
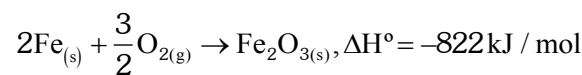

Then enthalpy change for following reaction

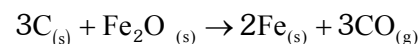

Ans. (492)

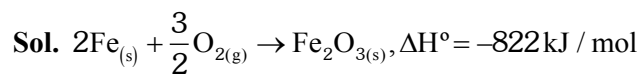

.....(1)

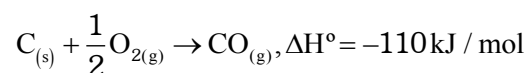

.....(2)

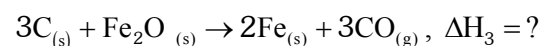

$$(3) = 3 \times (2) - (1)$$

$$\Delta H_3 = 3 \times \Delta H_2 - \Delta H_1$$

$$= 3(-110) + 822$$

$$= 492 \text{ kJ/mole}$$

- 84.** The total number of correct statements, regarding the nucleic acids is _____.
- A. RNA is regarded as the reserve of genetic information.
- B. DNA molecule self-duplicates during cell division
- C. DNA synthesizes proteins in the cell.
- D. The message for the synthesis of particular proteins is present in DNA
- E. Identical DNA strands are transferred to daughter cells.

Ans. (3)

- Sol.** A. RNA is regarded as the reserve of genetic information. (False)
- B. DNA molecule self-duplicates during cell division. (True)
- C. DNA synthesizes proteins in the cell. (False)
- D. The message for the synthesis of particular proteins is present in DNA. (True)
- E. Identical DNA strands are transferred to daughter cells. (True)

- 85.** The pH of an aqueous solution containing 1M benzoic acid ($pK_a = 4.20$) and 1M sodium benzoate is 4.5. The volume of benzoic acid solution in 300 mL of this buffer solution is _____ mL.

Ans. (100)

Sol.

	1M Benzoic acid	+	1M Sodium Benzoate
	(V_a ml)		(V ml)
Millimole	$V_a \times 1$		V 1

$$pH = 4.5$$

$$pH = pK_a + \log \frac{[\text{salt}]}{[\text{acid}]}$$

$$4.5 = 4.2 + \log \left(\frac{V_s}{V_a} \right)$$

$$\frac{V_s}{V_a} = 2 \quad \dots\dots(1)$$

$$V_s + V = 300 \quad \dots\dots(2)$$

$$V_a = 100 \text{ ml}$$

- 86.** Number of geometrical isomers possible for the given structure is/are _____.

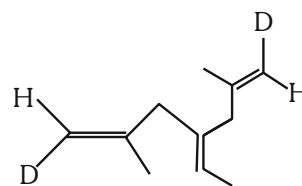

Ans. (4)

Sol. 3 stereocenters, symmetrical

Total Geometrical isomers \rightarrow 4. EE, ZZ, EZ (two isomers)

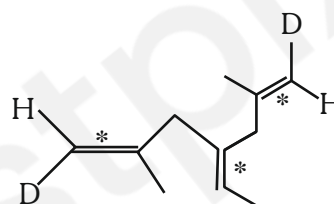

- 87.** Total number of species from the following which can undergo disproportionation reaction _____.

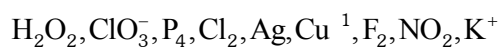

Ans. (6)

Sol. Intermediate oxidation state of element can undergo disproportionation.



- 88.** Number of metal ions characterized by flame test among the following is _____.

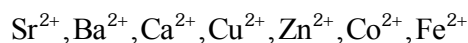

Ans. (4)

Sol. All the following metal ions will respond to flame test.

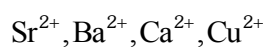

89. 2-chlorobutane + $\text{Cl}_2 \rightarrow \text{C}_4\text{H}_8\text{Cl}_2$ (isomers)
 Total number of optically active isomers shown by $\text{C}_4\text{H}_8\text{Cl}_2$, obtained in the above reaction is _____.

Ans. (6)

Sol.

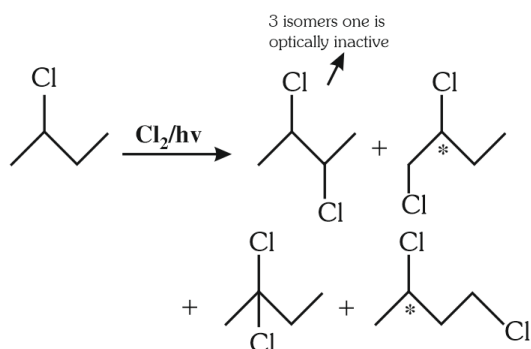

90. Number of spectral lines obtained in He^+ spectra, when an electron makes transition from fifth excited state to first excited state will be

Ans. (10)

Sol. 5th excited state $\Rightarrow n_1 = 6$

1st excited state $\Rightarrow n_2 = 2$

$$\Delta n = n_1 - n_2 = 6 - 2 = 4$$

Maximum number of spectral lines

$$= \frac{\Delta n(\Delta n + 1)}{2} = \frac{4(4 + 1)}{2} = 10$$