

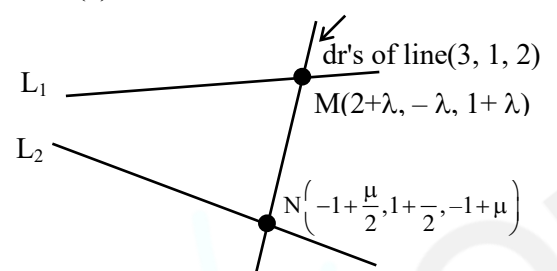

(Held On Tuesday 09th April, 2024)

TIME : 9 : 00 AM to 12 : 00 NOON

MATHEMATICS	TEST PAPER WITH SOLUTION
<p style="text-align: center;">SECTION-A</p> <p>1. Let the line L intersect the lines $x - 2 = -y = z - 1$, $2(x + 1) = 2(y - 1) = z + 1$ and be parallel to the line $\frac{x-2}{3} = \frac{y-1}{1} = \frac{z-2}{2}$. Then which of the following points lies on L ?</p> <p>(1) $\left(-\frac{1}{3}, 1, 1\right)$ (2) $\left(-\frac{1}{3}, 1, -1\right)$ (3) $\left(-\frac{1}{3}, -1, -1\right)$ (4) $\left(-\frac{1}{3}, -1, 1\right)$</p> <p>Ans. (2)</p> <p>Sol. </p> <p>$L_1: \frac{x-2}{1} = \frac{y}{-1} = \frac{z-1}{1} = \lambda$ $L_2: \frac{x+1}{\frac{1}{2}} = \frac{y-1}{-} = \frac{z+1}{1} = \mu$</p> <p>dr of line MN will be $\langle 3+\lambda, -1-\lambda, 2+\lambda-\mu \rangle$ & it will be proportional to $\langle 3, 1, 2 \rangle$</p> $\therefore \frac{3+\lambda}{3} = \frac{-1-\lambda}{1} = \frac{2+\lambda-\mu}{2}$ <div style="display: flex; justify-content: space-around; margin-top: 10px;"> <div style="text-align: center;">  $4\lambda + \mu = -6$ </div> <div style="text-align: center;">  $4 + 3\lambda = 0$ </div> </div>	$\Rightarrow \lambda = -\frac{4}{3} \text{ \& } \mu = -\frac{2}{3}$ <p>\therefore Coordinate of M will be $\left(\frac{2}{3}, \frac{4}{3}, -\frac{1}{3}\right)$ and equation of required line will be.</p> $\frac{x-\frac{2}{3}}{3} = \frac{y-\frac{4}{3}}{1} = \frac{z+\frac{1}{3}}{2} = k$ <p>So any point on this line will be $\left(\frac{2}{3} + 3k, \frac{4}{3} + k, -\frac{1}{3} + 2k\right)$</p> $\therefore \frac{2}{3} + 3k = -\frac{1}{3} \Rightarrow k = -\frac{1}{3}$ <p>\therefore Point lie on the line for $k = -\frac{1}{3}$ is $\left(-\frac{1}{3}, 1, 1\right)$</p> <p>2. The parabola $y^2 = 4x$ divides the area of the circle $x^2 + y^2 = 5$ in two parts. The area of the smaller part is equal to :</p> <p>(1) $\frac{2}{3} + 5 \sin^{-1}\left(\frac{2}{\sqrt{5}}\right)$ (2) $\frac{1}{3} + 5 \sin^{-1}\left(\frac{2}{\sqrt{5}}\right)$ (3) $\frac{1}{3} + \sqrt{5} \sin^{-1}\left(\frac{2}{\sqrt{5}}\right)$ (4) $\frac{2}{3} + \sqrt{5} \sin^{-1}\left(\frac{2}{\sqrt{5}}\right)$</p> <p>Ans. (1)</p> <p>Sol. $y^2 = 4x$ $x^2 + y^2 = 5$ \therefore Area of shaded region as shown in the figure will be</p>

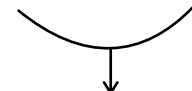
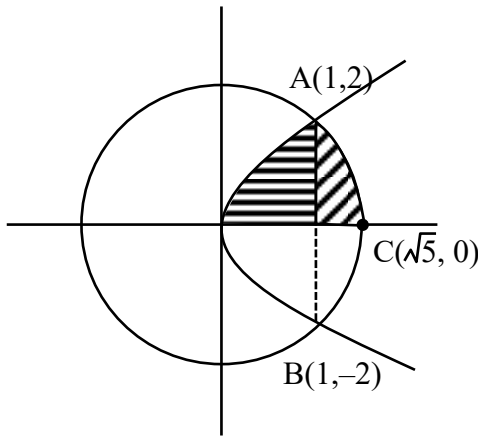

$$A_1 = \int_0^1 \sqrt{4x} \, dx + \int_0^1 \sqrt{5-x^2} \, dx$$

$$= \frac{4}{3} \left[x^{\frac{3}{2}} \right]_0^1 + \left[\frac{x}{2} \sqrt{5-x^2} + \frac{5}{2} \sin^{-1} \frac{x}{\sqrt{5}} \right]_0^1$$

$$= \frac{1}{3} + \frac{5\pi}{4} - \frac{5}{2} \sin^{-1} \left(\frac{1}{\sqrt{5}} \right)$$

∴ Required Area = 2 A₁

$$= \frac{2}{3} + \frac{5\pi}{2} - 5 \sin^{-1} \left(\frac{1}{\sqrt{5}} \right)$$

$$= \frac{2}{3} + 5 \left(\frac{\pi}{2} - \sin^{-1} \frac{1}{\sqrt{5}} \right)$$

$$= \frac{2}{3} + 5 \cos^{-1} \frac{1}{\sqrt{5}}$$

$$= \frac{2}{3} + 5 \sin^{-1} \left(\frac{2}{\sqrt{5}} \right)$$

3. The solution curve, of the differential equation

$$2y \frac{dy}{dx} + 3 = 5 \frac{dy}{dx}, \text{ passing through the point}$$

(0, 1) is a conic, whose vertex lies on the line :

- (1) $2x + 3y = 9$ (2) $2x + 3y = -9$
 (3) $2x + 3y = -6$ (4) $2x + 3y = 6$

Ans. (1)

Sol. $(2y-5) \frac{dy}{dx} = -3$

$$(2y-5)dy = -3dx$$

$$2 \cdot \frac{y^2}{2} - 5y = -3x + \lambda$$

∴ Curve passes through (0, 1)

$$\Rightarrow \lambda = -4$$

∴ Curve will be

$$\left(y - \frac{5}{2} \right)^2 = -3 \left(x - \frac{3}{4} \right)$$

∴ Vertex of parabola will be $\left(\frac{3}{4}, - \right)$

$$\therefore 2x + 3y = 9$$

4. A ray of light coming from the point P (1, 2) gets reflected from the point Q on the x-axis and then passes through the point R (4, 3). If the point S (h, k) is such that PQRS is a parallelogram, then hk^2 is equal to :

- (1) 80 (2) 90
 (3) 60 (4) 70

Ans. (4)

Sol.

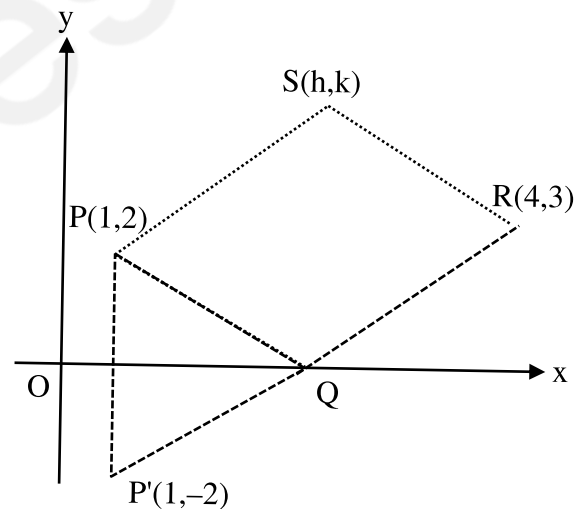

Image of P wrt x-axis will be P'(1, -2) equation of line joining P'R will be

$$y - 3 = \frac{5}{3}(x - 4)$$

Above line will meet x-axis at Q where

$$y = 0 \Rightarrow x = \frac{11}{5}$$

$$\therefore Q \left(\frac{11}{5}, 0 \right)$$

∴ PQRS is parallelogram so their diagonals will bisect each other

$$\Rightarrow \frac{4+1}{2} = \frac{11+h}{5} \& \frac{2+3}{2} = \frac{k+0}{2}$$

$$\Rightarrow h = \frac{14}{5} \& k = 5$$

$$\therefore hk^2 = \frac{14}{5} \times 5^2 = 70$$

5. Let $\lambda, \mu \in \mathbb{R}$. If the system of equations

$$3x + 5y + \lambda z = 3$$

$$7x + 11y - 9z = 2$$

$$97x + 155y - 189z = \mu$$

has infinitely many solutions, then $\mu + 2\lambda$ is equal to :

(1) 25 (2) 24

(3) 27 (4) 22

Ans. (1)

Sol. $3x + 5y + \lambda z = 3$

$$7x + 11y - 9z = 2$$

$$97x + 155y - 189z = \mu$$

$$93x + 155y + 31\lambda z = 93$$

$$97x + 155y - 189z = \mu$$

$$\underline{\quad - \quad + \quad - \quad}$$

$$-4x + (31\lambda + 189)z = 93 - \mu$$

$$1085x + 1705y - 1395z = 310$$

$$1067x + 1705y - 2079z = 11\mu$$

$$\underline{\quad - \quad + \quad - \quad}$$

$$18x + 684z = 310 - 11\mu$$

$$-36x + 9(31\lambda + 189)z = 9(93 - \mu)$$

$$36x + 1368z = 2(310 - 11\mu)$$

$$(279\lambda + 3069)z = 1457 - 31\mu$$

for infinite solutions -

$$\lambda = \frac{3069}{279} = \frac{-341}{31}$$

$$\mu = \frac{1457}{31}$$

$$\mu + 2\lambda = \frac{1457 - 682}{31} = \frac{775}{31} = 25$$

6. The coefficient of x^{70} in $x^2(1+x)^{98} + x^3(1+x)^{97} + x^4(1+x)^{96} + \dots + x^{54}(1+x)^{46}$ is ${}^{99}C_p - {}^{46}C_q$.

Then a possible value to $p + q$ is :

(1) 55 (2) 61

(3) 68 (4) 83

Ans. (4)

Sol. $x^2(1+x)^{98} + x^3(1+x)^{97} + x^4(1+x)^{96} + \dots + x^{54}(1+x)^{46}$

Coeff. of $x^{70} : {}^{98}C_{68} + {}^{97}C_{67} + {}^{96}C_{66} + \dots$

$${}^{47}C_{17} + {}^{46}C_{16}$$

$$= {}^{46}C_{30} + {}^{47}C_{30} + \dots + {}^{98}C_{30}$$

$$= ({}^{46}C_{31} + {}^{46}C_{30}) + {}^{47}C_{30} + \dots + {}^{98}C_{30} - {}^{46}C_{31}$$

$$= {}^{47}C_{31} + {}^{47}C_{30} + \dots + {}^{98}C_{30} - {}^{46}C_{31}$$

.....

$$= {}^{99}C_{31} - {}^{46}C_{31} = {}^{99}C_p - {}^{46}C_q$$

Possible values of $(p + q)$ are 62, 83, 99, 46

$$\Rightarrow p + q = 83$$

7. Let

$$\int \frac{2 - \tan x}{3 + \tan x} dx = \frac{1}{2} (\alpha x + \log_e |\beta \sin x + \gamma \cos x|) + C$$

, where C is the constant of integration.

Then $\alpha + \frac{\gamma}{\beta}$ is equal to :

(1) 3 (2) 1

(3) 4 (4) 7

Ans. (3)

Sol. $\int \frac{2 - \tan x}{3 + \tan x} dx = \int \frac{2 \cos x - \sin x}{3 \cos x + \sin x} dx$

$$2 \cos x - \sin x = A(3 \cos x + \sin x) + B(\cos x - 3 \sin x)$$

$$3A + B = 2$$

$$A - 3B = -1$$

$$\Rightarrow A = \frac{1}{2}, B = \frac{1}{2}$$

$$\therefore \int \frac{2 \cos x - \sin x}{3 \cos x + \sin x} dx$$

$$= \frac{x}{2} + \frac{1}{2} \ln |3 \cos x + \sin x| + C$$

$$= \frac{1}{2} (x + \ln |3 \cos x + \sin x|) + C$$

$$= \frac{1}{2} (\alpha x + \ln |\beta \sin x + \gamma \cos x|) + C$$

$$\alpha = 1, \beta = 1, \gamma = 3$$

$$\therefore \alpha + \frac{\gamma}{\beta} = 1 + \frac{3}{1} = 4$$

8. A variable line L passes through the point (3, 5) and intersects the positive coordinate axes at the points A and B. The minimum area of the triangle OAB, where O is the origin, is :

- (1) 30
- (2) 25
- (3) 40
- (4) 35

Ans. (1)

Sol. $\frac{x}{a} + \frac{y}{b} = 1$

$$\frac{3}{a} + \frac{5}{b} = 1 \Rightarrow b = \frac{5a}{a-3}, a > 3$$

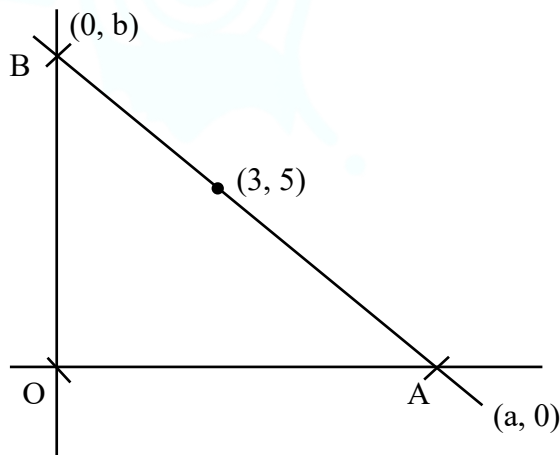

$$A = \frac{1}{2} ab = \frac{1}{2} a \frac{5a}{a-3} = \frac{5}{2} \cdot \frac{a^2}{a-3}$$

$$= \frac{5}{2} \left(\frac{a^2 - 9 + 9}{a-3} \right)$$

$$= \frac{5}{2} \left(a + 3 + \frac{9}{a-3} \right)$$

$$= \frac{5}{2} \left(a - 3 + \frac{9}{a-3} + 6 \right) \geq 30$$

9. Let

$$|\cos \theta \cos(60 - \theta) \cos(60 + \theta)| \leq \frac{1}{8}, \theta \in [0, 2\pi]$$

Then, the sum of all $\theta \in [0, 2\pi]$, where $\cos 3\theta$ attains its maximum value, is :

- (1) 9π
- (2) 18π
- (3) 6π
- (4) 15π

Ans. (3)

Sol. We know that

$$(\cos \theta) (\cos (60^\circ - \theta)) (\cos (60^\circ + \theta)) = \frac{1}{4} \cos 3\theta$$

So equation reduces to $\left| \frac{1}{4} \cos 3\theta \right| = \frac{1}{8}$

$$\Rightarrow |\cos 3\theta| = \frac{1}{2}$$

$$\Rightarrow -\frac{1}{2} \leq \cos 3\theta \leq \frac{1}{2}$$

$$\Rightarrow \text{maximum value of } \cos 3\theta = \frac{1}{2}, \text{ here}$$

$$\Rightarrow 3\theta = 2n\pi \pm \frac{\pi}{3}$$

$$\theta = \frac{2n\pi}{3} \pm \frac{\pi}{9}$$

As $\theta \in [0, 2\pi]$ possible values are

$$\theta \in \left\{ \frac{\pi}{9}, \frac{5\pi}{9}, \frac{7\pi}{9}, \frac{11\pi}{9}, \frac{13\pi}{9}, \frac{17\pi}{9} \right\}$$

Whose sum is

$$\frac{\pi}{9} + \frac{5\pi}{9} + \frac{7\pi}{9} + \frac{11\pi}{9} + \frac{13\pi}{9} + \frac{17\pi}{9} = \frac{54\pi}{9} = 6\pi$$

10. Let $\vec{OA} = 2\vec{a}, \vec{OB} = 6\vec{a} + 5\vec{b}$ and $\vec{OC} = 3\vec{b}$, where O is the origin. If the area of the parallelogram with adjacent sides \vec{OA} and \vec{OC} is 15 sq. units, then the area (in sq. units) of the quadrilateral OABC is equal to :

- (1) 38 (2) 40
(3) 32 (4) 35

Ans. (4)

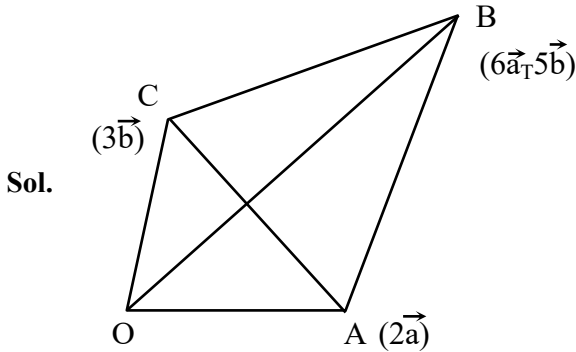

Area of parallelogram having sides \vec{OA} & $\vec{OC} = |\vec{OA} \times \vec{OC}| = |2\vec{a} \times 3\vec{b}| = 15$

$$6|\vec{a} \times \vec{b}| = 15$$

$$\Rightarrow |\vec{a} \times \vec{b}| = \frac{5}{2} \dots\dots(1)$$

Area of quadrilateral

$$\begin{aligned} \text{OABC} &= \frac{1}{2} |\vec{d}_1 \cdot \vec{d}| \\ &= \frac{1}{2} |\vec{AC} \cdot \vec{OB}| = \frac{1}{2} |(3\vec{b} - 2\vec{a}) \times (6\vec{a} + 5\vec{b})| \\ &= \frac{1}{2} |18\vec{b} \times \vec{a} - 10\vec{a} \times \vec{b}| = 14|\vec{a} \times \vec{b}| \\ &= 14 \times \frac{5}{2} = 35 \end{aligned}$$

11. If the domain of the function

$$f(x) = \sin^{-1}\left(\frac{x-1}{2x+3}\right) \text{ is } R - (\alpha, \beta)$$

then $12\alpha\beta$ is equal to :

- (1) 36 (2) 24
(3) 40 (4) 32

Ans. (4)

Sol. Domain of $f(x) = \sin^{-1}\left(\frac{x-1}{2x+3}\right)$ is

$$2x+3 \neq 0 \ \& \ x \neq \frac{-3}{2} \ \text{and} \ \left|\frac{x-1}{2x+3}\right| \leq 1$$

$$|x-1| \leq |2x+3|$$

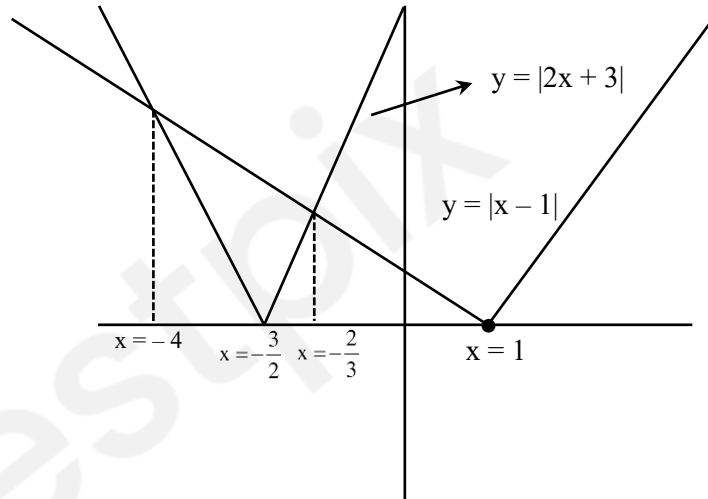

$$\text{For } |2x+3| \geq |x-1|$$

$$x \in (-\infty, -4] \cup \left[-\frac{2}{3}, \infty\right)$$

$$\alpha = -4 \ \& \ \beta = -\frac{2}{3} : 12\alpha\beta = 32$$

12. If the sum of series

$$\frac{1}{1 \cdot (1+d)} + \frac{1}{(1+d)(1+2d)} + \dots + \frac{1}{(1+9d)(1+10d)}$$

is equal to 5, then $50d$ is equal to :

- (1) 20 (2) 5
(3) 15 (4) 10

Ans. (2)

Sol. $\frac{1}{1 \cdot (1+d)} - \frac{1}{(1+d)(1+2d)} + \dots$

$$\frac{1}{(1+9d)(1+10d)} = 5$$



$$\frac{1}{d} \left[\frac{(1+d)-1}{1 \cdot (1+d)} + \frac{(1+2d)-(1-d)}{(1+d)(1+2d)} \right] + \dots$$

$$\frac{(1+10d)-(1+9d)}{(1+9d)(1+10d)} = 5$$

$$\frac{1}{d} \left[\left(1 - \frac{1}{1+d} \right) + \left(\frac{1}{1+d} - \frac{1}{1+2d} \right) \right] + \dots$$

$$\left(\frac{1}{1+9d} - \frac{1}{1+10d} \right) = 5$$

$$\frac{1}{d} \left[1 - \frac{1}{(1+10d)} \right] = 5$$

$$\frac{10d}{1+10d} = 5d$$

$$50d = 5$$

13. Let $f(x) = ax^3 + bx^2 + cx + 41$ be such that

$$f(1) = 40, f'(1) = 2 \text{ and } f''(1) = 4.$$

Then $a^2 + b^2 + c^2$ is equal to :

(1) 62

(2) 73

(3) 54

(4) 51

Ans. (4)

Sol. $f(x) = ax^3 + bx^2 + cx + 41$

$$f'(x) = 3ax^2 + 2bx + c$$

$$\Rightarrow f'(1) = 3a + 2b + c = 2 \dots (1)$$

$$f''(x) = 6ax + 2b$$

$$\Rightarrow f''(1) = 6a + 2b = 4$$

$$3a + b = 2 \dots (2)$$

(1) - (2)

$$b + c = 0 \dots (3)$$

$$f(1) = 40$$

$$a + b + c + 41 = 40$$

use (3)

$$a + 41 = 40$$

by (2)

$$-3 + b = 2 \Rightarrow b = 5 \text{ \& } c = -5$$

$$a^2 + b^2 + c^2 = 1 + 25 + 25 = 51$$

14. Let a circle passing through (2, 0) have its centre at the point (h, k). Let (x_c, y_c) be the point of intersection of the lines $3x + 5y = 1$ and $(2 + c)x + 5c^2y = 1$. If $h = \lim_{c \rightarrow 1} x_c$ and $k = \lim_{c \rightarrow 1} y_c$, then the equation of the circle is :

(1) $25x^2 + 25y^2 - 20x + 2y - 60 = 0$

(2) $5x^2 + 5y^2 - 4x - 2y - 12 = 0$

(3) $25x^2 + 25y^2 - 2x + 2y - 60 = 0$

(4) $5x^2 + 5y^2 - 4x + 2y - 12 = 0$

Ans. (1)

Sol. $(2 + c)x + 5c^2 \left(\frac{1 - 3x}{5} \right) = 1$

$$x = \frac{1 - c^2}{2 + c - 3c^2}, y = \frac{1 - 3x}{5} = \frac{c - 1}{5(2 + c - 3c^2)}$$

$$h = \lim_{c \rightarrow 1} \frac{(1 - c)(1 + c)}{(1 - c)(2 + 3c)} = \frac{2}{5}$$

$$K = \lim_{c \rightarrow 1} \frac{c - 1}{-5(c - 1)(3c + 2)} = -\frac{1}{25}$$

Centre $\left(\frac{2}{25}, -\frac{1}{25} \right)$,

$$r = \sqrt{\left(2 - \frac{2}{25} \right)^2 + \left(0 - \frac{1}{25} \right)^2} = \sqrt{\frac{64}{25} + \frac{1}{625}}$$

$$r = \frac{\sqrt{161}}{25}$$

$$\left(x - \frac{2}{5} \right)^2 + \left(y + \frac{1}{25} \right)^2 = \frac{161}{125}$$

$$\Rightarrow 25x^2 + 25y^2 - 20x + 2y - 60 = 0$$

15. The shortest distance between the line

$$\frac{x - 3}{4} = \frac{y - 7}{-11} = \frac{z - 1}{5} \text{ and } \frac{x - 5}{3} = \frac{y - 9}{-6} = \frac{z + 2}{1}$$

is :

(1) $\frac{187}{\sqrt{563}}$

(2) $\frac{178}{\sqrt{563}}$

(3) $\frac{185}{\sqrt{563}}$ (4) $\frac{179}{\sqrt{563}}$

Ans. (1)

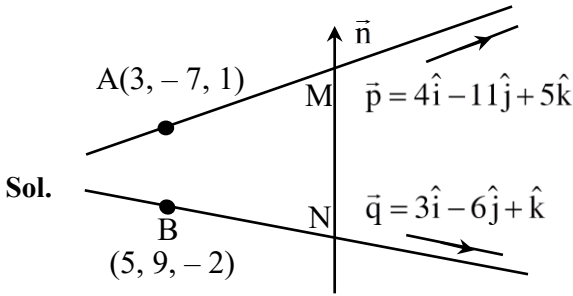

Sol.

$$\vec{n} = \vec{p} \times \vec{q}$$

$$\vec{n} = \begin{vmatrix} \hat{i} & \hat{j} & \hat{k} \\ 4 & -11 & 5 \\ 3 & -6 & 1 \end{vmatrix} = 19\hat{i} + 11\hat{j} + 9\hat{k}$$

S.d. = projection of \overline{AB} on \vec{n}

$$= \frac{|\overline{AB} \cdot \vec{n}|}{|\vec{n}|} = \frac{|(2\hat{i} + 16\hat{j} - 3\hat{k}) \cdot (19\hat{i} + 11\hat{j} + 9\hat{k})|}{\sqrt{361 + 121 + 81}}$$

$$= \frac{38 + 176 - 27}{\sqrt{563}}$$

$$\text{S.d.} = \frac{187}{\sqrt{563}}$$

16. The frequency distribution of the age of students in a class of 40 students is given below.

Age	15	16	17	18	19	20
No. of Students	5	8	5	12	x	y

If the mean deviation about the median is 1.25, then $4x + 5y$ is equal to :

- (1) 43 (2) 44
 (3) 47 (4) 46

Ans. (2)

Sol. $x + y = 10$ (1)

Median = 18 = M

$$\text{M.D.} = \frac{\sum f_i |x_i - M|}{\sum f_i}$$

$$1.25 = \frac{36 + x + 2y}{40}$$

$x + 2y = 14$ (2)

by (1) & (2)

$x = 6, y = 4$

$\Rightarrow 4x + 5y = 24 + 20 = 44$

Age(x_i)	f	$ x_i - M $	$f_i x_i - M $
15	5	3	15
16	8	2	16
17	5	1	5
18	12	0	0
19	x	1	x
20	y	2	2y

17. The solution of the differential equation

$(x^2 + y^2)dx - 5xy dy = 0, y(1) = 0$, is :

- (1) $|x^2 - 4y^2|^5 = x^2$ (2) $|x^2 - 2y^2|^6 = x$
 (3) $|x - 4y^2|^6 = x$ (4) $|x^2 - 2y^2|^5 = x^2$

Ans. (1)

Sol. $(x^2 + y^2) dx = 5xy dy$

$$\Rightarrow \frac{dy}{dx} = \frac{x^2 + y}{5xy}$$

Put $y = Vx$

$$\Rightarrow V + \frac{dV}{dx} = \frac{1 + V^2}{5V}$$

$$\Rightarrow \frac{xdV}{dx} = \frac{1 - 4V^2}{5V}$$

$$\frac{V}{1 - 4V^2} dV = \int \frac{dx}{5x}$$

Let $1 - 4V^2 = t$

$\Rightarrow -8V dV = dt$

$$\Rightarrow \frac{dt}{(-8)(t)} \int \frac{dx}{5x}$$

$$\Rightarrow \frac{-1}{8} \ln|t| = \frac{1}{5} \ln|x| + \ln C$$

$$\Rightarrow -5 \ln|t| = 8 \ln|x| + \ln K$$

$$\Rightarrow \ln x^8 + \ln |t^5| + \ln K = 0$$

$$\Rightarrow x^8 |t^5| = C$$

$$\Rightarrow x^8 |1 - 4V^2|^5 = C$$

$$x^8 \left| \frac{x^2 - 4y^2}{x^2} \right|^5 = C$$

$$\Rightarrow |x^2 - 4y^2|^5 = Cx^2$$

given $y(1) = 0$

$$\Rightarrow |1|^5 = C \Rightarrow C = 1$$

$$\Rightarrow |x^2 - 4y^2|^5 = x^2$$

18. Let three vectors $\vec{a} = \alpha\hat{i} + 4\hat{j} + 2\hat{k}$,
 $\vec{b} = 5\hat{i} + 3\hat{j} + 4\hat{k}$, $\vec{c} = x\hat{i} + y\hat{j} + z\hat{k}$ form a triangle
 such that $\vec{c} = \vec{a} - \vec{b}$ and the area of the triangle is
 $5\sqrt{6}$. if α is a positive real number, then $|\vec{c}|^2$ is :

- (1) 16 (2) 14
 (3) 12 (4) 10

Ans. (2)

Sol. $\vec{c} = \vec{a} - \vec{b}$

$$\Rightarrow (x, y, z) = (\alpha - 5, 1, -2)$$

$$\Rightarrow x = \alpha - 5, y = 1, z = -2 \quad \dots\dots(1)$$

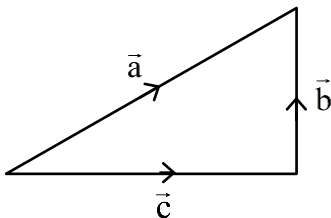

Area of $\Delta = 5\sqrt{6}$ (given)

$$\frac{1}{2} |\vec{a} \times \vec{c}| = 5\sqrt{6}$$

$$\left\| \begin{matrix} \hat{i} & \hat{j} & \hat{k} \\ \alpha & 4 & \\ x & 1 & -2 \end{matrix} \right\| = 10\sqrt{6}$$

$$\Rightarrow |-10\hat{i} - \hat{j}(-2\alpha - 2x) + \hat{k}(\alpha - 4x)| = 10\sqrt{6}$$

$$\Rightarrow (2\alpha + 2\alpha - 10)^2 + (\alpha - 4\alpha + 20)^2 = 500$$

$$\Rightarrow (4\alpha - 10)^2 + (20 - 3\alpha)^2 = 500$$

$$\Rightarrow 25\alpha^2 - 80\alpha - 120\alpha = 0$$

$$\Rightarrow \alpha(25\alpha - 200) = 0$$

$$\Rightarrow \alpha = 8 \text{ (given } \alpha \text{ is +ve number)}$$

$$\Rightarrow x = \alpha - 5 = 3$$

$$|\vec{c}|^2 = x^2 + y^2 + z^2$$

$$= 9 + 1 + 4$$

$$= 14$$

19. Let α, β be the roots of the equation

$$x^2 + 2\sqrt{2}x - 1 = 0. \text{ The quadratic equation,}$$

whose roots are $\alpha^4 + \beta^4$ and $\frac{1}{10}(\alpha^6 + \beta^6)$, is :

- (1) $x^2 - 190x + 9466 = 0$
 (2) $x^2 - 195x + 9466 = 0$
 (3) $x^2 - 195x + 9506 = 0$
 (4) $x^2 - 180x + 9506 = 0$

Ans. (3)

Sol. $x^2 + 2\sqrt{2}x - 1 = 0$

$$\alpha + \beta = -2\sqrt{2}$$

$$\alpha\beta = -1$$

$$\alpha^4 + \beta^4 = (\alpha^2 + \beta^2)^2 - 2\alpha^2\beta^2$$

$$= ((\alpha + \beta)^2 - 2\alpha\beta)^2 - 2(\alpha\beta)^2$$

$$= (8 + 2)^2 - 2(-1)^2$$

$$= 100 - 2 = 98$$

$$\alpha^6 + \beta^6 = (\alpha^3 + \beta^3)^2 - 2\alpha^3\beta^3$$

$$= ((\alpha + \beta) ((\alpha + \beta)^2 - 3\alpha\beta))^2 - 2(\alpha\beta)^3$$



$$= (-2\sqrt{2}(8+3))^2 + 2$$

$$= (8)(121) + 2 = 970$$

$$\frac{1}{10}(\alpha^6 + \beta^6) = 97$$

$$x^2 - (98 + 97)x + (98)(97) = 0$$

$$\Rightarrow x^2 - 195x + 9506 = 0$$

20. Let $f(x) = x^2 + 9$, $g(x) = \frac{x}{x-9}$ and

$a = fog(10)$, $b = gof(3)$. If e and l denote the eccentricity and the length of the latus rectum of

the ellipse $\frac{x^2}{a} + \frac{y^2}{b} = 1$, then $8e^2 + l^2$ is equal to.

(1) 16

(2) 8

(3) 6

(4) 12

Ans. (2)

Sol. $f(x) = x^2 + 9$ $g(x) = \frac{x}{x-9}$

$$a = f(g(10)) = f\left(\frac{10}{10-9}\right)$$

$$= f(10) = 109$$

$$b = g(f(3)) = g(9+9)$$

$$= g(18) = \frac{18}{9} = 2$$

$$E: \frac{x^2}{109} + \frac{y^2}{2} = 1$$

$$e^2 = 1 - \frac{2}{109} = \frac{107}{109}$$

$$l = \frac{(2)}{\sqrt{109}} \cdot \frac{4}{\sqrt{109}}$$

$$8e^2 + l = \frac{8(107)}{109} + \frac{16}{109}$$

$$= 8$$

SECTION-B

21. Let a , b and c denote the outcome of three independent rolls of a fair tetrahedral die, whose

four faces are marked 1, 2, 3, 4. If the probability

that $ax^2 + bx + c = 0$ has all real roots is $\frac{m}{n}$,

$\gcd(m, n) = 1$, then $m + n$ is equal to _____.

Ans. (19)

Sol. $a, b, c \in \{1, 2, 3, 4\}$

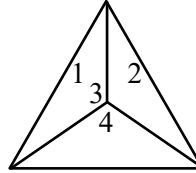

Tetrahedral dice

$$ax^2 + bx + c = 0$$

has all real roots

$$\Rightarrow D \geq 0$$

$$\Rightarrow b^2 - 4ac \geq 0$$

$$\text{Let } b = 1 \Rightarrow 1 - 4ac \geq 0 \text{ (Not feasible)}$$

$$b = 2 \Rightarrow 4 - 4ac \geq 0$$

$$1 \geq ac \Rightarrow a = 1, c = 1,$$

$$b = 3 \Rightarrow 9 - 4ac \geq 0$$

$$\frac{9}{4} \geq ac$$

$$\Rightarrow a = 1, c = 1$$

$$\Rightarrow a = 1, c = 2$$

$$\Rightarrow a = 2, c = 1$$

$$b = 4 \Rightarrow 16 - 4ac \geq 0$$

$$4 \geq ac$$

$$\Rightarrow a = 1, c = 1$$

$$\Rightarrow a = 1, c = 2 \quad \Rightarrow a = 2, c = 1$$

$$\Rightarrow a = 1, c = 3 \quad \Rightarrow a = 3, c = 1$$

$$\Rightarrow a = 1, c = 4 \quad \Rightarrow a = 4, c = 1$$

$$\Rightarrow a = 2, c = 2$$

$$\text{Probability} = \frac{12}{(4)(4)(4)} = \frac{3}{16} = \frac{m}{n}$$

$$m + n = 19$$

22. The sum of the square of the modulus of the elements in the set

$$\{z = a + ib : a, b \in \mathbb{Z}, z \in \mathbb{C}, |z-1| \leq 1, |z-5| \leq |z-5i|\}$$

is _____.

Ans. (9)

Sol. $|z-1| \leq 1$

$$\Rightarrow |(x-1) + iy| \leq 1$$

$$\Rightarrow \sqrt{(x-1)^2 + y^2} \leq 1$$

$$\Rightarrow (x-1)^2 + y^2 \leq 1 \dots\dots\dots (1)$$

Also $|z-5| \leq |z-5i|$

$$(x-5)^2 + y^2 \leq x^2 + (y-5)^2$$

$$-10x \leq -10y$$

$$\Rightarrow x \geq y \dots\dots\dots (2)$$

Solving (1) and (2)

$$\Rightarrow (x-1)^2 + x^2 = 1$$

$$\Rightarrow 2x^2 - 2x = 0$$

$$\Rightarrow x(x-1) = 0$$

$$\Rightarrow x = 0 \text{ or } x = 1$$

$$y = 0 \text{ or } y = 1$$

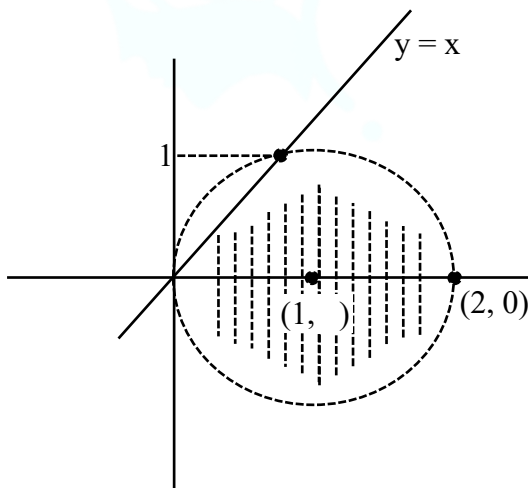

Given $x, y \in \mathbb{I}$

Points (0, 0), (1, 0), (2, 0), (1, 1), (1, -1) to find

$$|z_1|^2 + |z_2|^2 + |z_3|^2 + |z_4|^2 + |z_5|^2$$

$$= 0 + 1 + 4 + 1 + 1 + 1 + 1 = 9$$

23. Let the set of all positive values of λ , for which the point of local minimum of the function

$$(1 + x(\lambda^2 - x^2)) \text{ satisfies } \frac{x^2 + x + 2}{x^2 + 5x + 6} < 0, \text{ be } (\alpha, \beta).$$

Then $\alpha^2 + \beta^2$ is equal to _____.

Ans. (39)

Sol. $\frac{x^2 + x + 2}{x^2 + 5x + 6} < 0$

$$\Rightarrow \frac{1}{(x+2)(x+3)} < 0$$

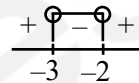

$$x \in (-3, -2) \dots\dots\dots (1)$$

$$f(x) = 1 + x(\lambda^2 - x^2)$$

Finding local minima

$$f'(x) = (\lambda^2 - x^2) + (-2x) \cdot x$$

Put $f'(x) = 0$

$$\Rightarrow \lambda^2 = 3x^2$$

$$\Rightarrow x = \pm \frac{\lambda}{\sqrt{3}}$$

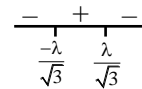

Local min Local max

We want local min

$$\Rightarrow x = \frac{-\lambda}{\sqrt{3}}$$

from (1)

$$x \in (-3, -2)$$

$$-3 < \frac{-\lambda}{\sqrt{3}} < -2$$

$$3\sqrt{3} > \lambda > 2\sqrt{3}$$

$$\alpha = 2\sqrt{3}, \beta = 3\sqrt{3}$$

$$\alpha + \beta^2 = 12 + 27 = 39$$

24. Let

$$\lim_{n \rightarrow \infty} \left(\frac{n}{\sqrt{n^4+1}} - \frac{2n}{(n^2+1)\sqrt{n^4+1}} + \frac{n}{\sqrt{n^4+16}} - \frac{8n}{(n^2+4)\sqrt{n^4+16}} + \dots + \frac{n}{\sqrt{n^4+n^4}} - \frac{2n \cdot n^2}{(n^2+n^2)\sqrt{n^4+n^4}} \right) \text{ be } \frac{\pi}{k},$$

using only the principal values of the inverse trigonometric functions. Then k^2 is equal to _____.

Ans. (32)

Sol.
$$\sum_{r=1}^{\infty} \frac{n}{\sqrt{n^4+r^4}} - \frac{2nr^2}{(n^2+r^2)\sqrt{n^4+r^4}}$$

$$\sum_{r=1}^{\infty} \frac{\frac{1}{n}}{\sqrt{1+\left(\frac{r}{n}\right)^4}} - \frac{2\left(\frac{1}{n}\right)\left(\frac{r}{n}\right)^2}{\left(1+\left(\frac{r}{n}\right)^2\right)\sqrt{1+\left(\frac{r}{n}\right)^4}}$$

$$\Rightarrow \int_0^1 \frac{dx}{\sqrt{1+x^4}} - \frac{2x^2 dx}{(1+x^2)\sqrt{1+x^4}}$$

$$\Rightarrow \int_0^1 \frac{1-x^2}{(1+x^2)\sqrt{1-x^2}} dx$$

$$\Rightarrow \int_0^1 \frac{\frac{1}{x^2}-1}{\left(\frac{-1}{x}\right)\sqrt{x^2+\frac{1}{2}}} dx$$

$$\Rightarrow -\int_0^1 \frac{1-\frac{1}{x^2}}{\left(x+\frac{1}{x}\right)\sqrt{\left(x+\frac{1}{x}\right)^2-2}} dx$$

$$x + \frac{1}{x} = t \Rightarrow 1 - \frac{1}{x^2} dx = dt$$

$$\Rightarrow -\int_{\infty}^2 \frac{dt}{t\sqrt{t^2-2}}$$

$$\Rightarrow -\int_{\infty}^2 \frac{tdt}{t^2\sqrt{t^2-2}}$$

$$\text{take } t^2 - 2 = \alpha^2$$

$$t dt = \alpha d\alpha$$

$$\Rightarrow -\int_{\infty}^{\sqrt{2}} \frac{\alpha d\alpha}{(\alpha^2+2)\alpha}$$

$$\Rightarrow -\int_{\infty}^{\sqrt{2}} \frac{d\alpha}{\alpha^2+2}$$

$$\Rightarrow \left. \frac{-1}{\sqrt{2}} \tan^{-1} \frac{\alpha}{\sqrt{2}} \right]_{\infty}^{\sqrt{2}}$$

$$\Rightarrow \frac{-1}{\sqrt{2}} \{ \tan^{-1} 1 \} + \frac{1}{\sqrt{2}} \tan^{-1} \infty$$

$$\Rightarrow \frac{1}{\sqrt{2}} \left\{ \frac{\pi}{2} - \frac{\pi}{4} \right\}$$

$$\Rightarrow \frac{\pi}{4\sqrt{2}} = \frac{\pi}{K}$$

$$\text{So } K = 4\sqrt{2}$$

$$K^2 = 32$$

25. The remainder when 428^{2024} is divided by 21 is _____.

Ans. (1)

Sol. $(428)^{2024} = (420 + 8)^{2024}$

$$= (21 \times 20 + 8)^{2024}$$

$$= 21m + 8^{2024}$$

$$\text{Now } 8^{2024} = (8^2)^{1012}$$

$$= (64)^{1012}$$

$$= (63 + 1)^{1012}$$

$$= (21 \times 3 + 1)^{1012}$$

$$= 21n + 1$$

$$\Rightarrow \text{Remainder is 1.}$$

26. Let $f: (0, \pi) \rightarrow \mathbb{R}$ be a function given by

$$f(x) = \begin{cases} \left(\frac{8}{7}\right)^{\frac{\tan 8x}{\tan 7x}}, & 0 < x < \frac{\pi}{2} \\ a - 8, & x = \frac{\pi}{2} \\ (1 + |\cot x|)^{\frac{b}{a}|\tan x|}, & \frac{\pi}{2} < x < \pi \end{cases}$$

Where $a, b \in \mathbb{Z}$. If f is continuous at $x = \frac{\pi}{2}$, then

$a^2 + b^2$ is equal to _____.

Ans. (81)

Sol. LHL at $x = \frac{\pi}{2}$

$$\lim_{x \rightarrow \frac{\pi}{2}^-} \left(\frac{8}{7}\right)^{\frac{\tan 8x}{\tan 7x}} = \left(\frac{8}{7}\right)^0 = 1$$

RHL at $x = \frac{\pi}{2}$

$$\lim_{x \rightarrow \frac{\pi}{2}^+} (1 + |\cot x|)^{\frac{b}{a}|\tan x|}$$

$$= e^{\lim_{x \rightarrow \frac{\pi}{2}^+} |\cot x| \frac{b}{a} |\tan x|} = e^{\frac{b}{a}}$$

$$\Rightarrow 1 = a - 8 = e^{\frac{b}{a}}$$

$$\Rightarrow a = 9, b = 0$$

$$\Rightarrow a^2 + b^2 = 81$$

27. Let A be a non-singular matrix of order 3. If $\det(3\text{adj}(2\text{adj}((\det A)A))) = 3^{-13} \cdot 2^{-10}$ and $\det(3\text{adj}(2A)) = 2^m \cdot 3^n$, then $|3m + 2n|$ is equal to _____.

Ans. (14)

Sol. $|3 \text{adj}(2\text{adj}(|A|A))| = |3\text{adj}(2|A|^2 \text{adj}(A))|$
 $= |3 \cdot 2^2 |A|^4 \text{adj}(\text{adj}(A))| = 2^6 3^3 |A|^{12} |A|^4$
 $= 2^6 3^3 |A|^{16} = 2^{-10} 3^{-13}$
 $\Rightarrow |A|^{16} = 2^{-16} 3^{-16} \Rightarrow |A| = 2^{-1} 3^{-1}$

$$\begin{aligned} \text{Now } |3\text{adj}(2A)| &= |3 \cdot 2^2 \text{adj}(A)| \\ &= 2^6 3^3 |A|^2 = 2^{-m} 3^{-n} \\ \Rightarrow 2^6 3^3 2^{-2} 3^{-2} &= 2^{-m} 3^{-n} \\ \Rightarrow 2^{-m} 3^{-n} &= 2^4 3^1 \\ \Rightarrow m &= -4, n = -1 \\ \Rightarrow |3m + 2n| &= |-12 - 2| = 14 \end{aligned}$$

28. Let the centre of a circle, passing through the point $(0, 0)$, $(1, 0)$ and touching the circle $x^2 + y^2 = 9$, be (h, k) . Then for all possible values of the coordinates of the centre (h, k) , $4(h^2 + k^2)$ is equal to _____.

Ans. (9)

Sol.

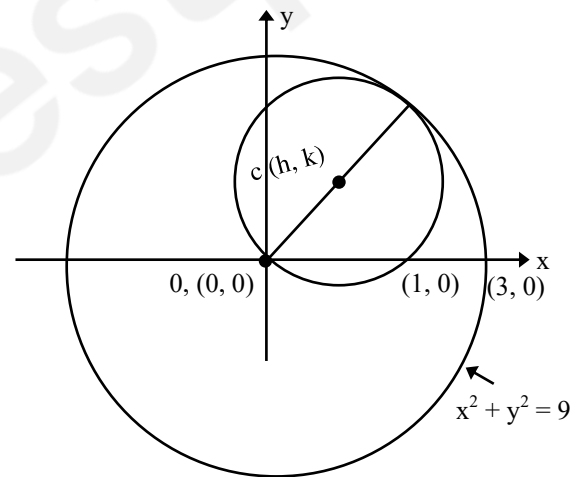

$$(x - h)^2 + (y - k)^2 = h^2 + k^2$$

$$x^2 + y^2 - 2hx - 2ky = 0$$

\therefore passes through $(1, 0)$

$$\Rightarrow 1 + 0 - 2h = 0$$

$$\Rightarrow h = 1/2$$

$$\therefore OC = \frac{OP}{2}$$

$$\sqrt{\left(\frac{1}{2}\right)^2 + k^2} = \frac{3}{2}$$

$$\frac{1}{4} + k^2 = \frac{9}{4}$$

$$k^2 = 2$$

$$k = \pm \sqrt{2}$$

∴ Possible coordinate of

$$c(h, k) \left(\frac{1}{2}, \sqrt{2} \right) \left(\frac{1}{2}, -\sqrt{2} \right)$$

$$4(h^2 + k^2) = 4 \left(\frac{1}{4} + 2 \right) = 4 \left(\frac{9}{4} \right) = 9$$

29. If a function f satisfies $f(m + n) = f(m) + f(n)$ for all $m, n \in \mathbb{N}$ and $f(1) = 1$, then the largest natural number λ such that $\sum_{k=1}^{2022} f(\lambda + k) \leq (2022)^2$ is equal to _____.

Ans. (1010)

Sol. $f(m + n) = f(m) + f(n)$

$$\Rightarrow f(x) = kx$$

$$\Rightarrow f(1) = 1$$

$$\Rightarrow k = 1$$

$$f(x) = x$$

Now

$$\sum_{k=1}^{2022} f(\lambda + k) \leq (2022)^2$$

$$\Rightarrow \sum_{k=1}^{2022} (\lambda + k) \leq (2022)^2$$

$$\Rightarrow 2022\lambda + \frac{2022 \times 2023}{2} \leq (2022)^2$$

$$\Rightarrow \lambda \leq 2022 - \frac{2023}{2}$$

$$\Rightarrow \lambda \leq 1010.5$$

∴ largest natural no. λ is 1010.

30. Let $A = \{2, 3, 6, 7\}$ and $B = \{4, 5, 6, 8\}$. Let R be a relation defined on $A \times B$ by $(a_1, b_1) R (a_2, b_2)$ is and only if $a_1 + a_2 = b_1 + b_2$. Then the number of elements in R is _____.

Ans. (25)

Sol. $A = \{2, 3, 6, 7\}$

$B = \{2, 5, 6, 8\}$

$(a_1, b_1) R (a_2, b_2)$

$a_1 + a_2 = b_1 + b_2$

- | | |
|---------------------|---------------------|
| 1. (2, 4) R (6, 4) | 2. (2, 4) R (7, 5) |
| 3. (2, 5) R (7, 4) | 4. (3, 4) R (6, 5) |
| 5. (3, 5) R (6, 4) | 6. (3, 5) R (7, 5) |
| 7. (3, 6) R (7, 4) | 8. (3, 4) R (7, 6) |
| 9. (6, 5) R (7, 8) | 10. (6, 8) R (7, 5) |
| 11. (7, 8) R (7, 6) | 12. (6, 8) R (6, 4) |
| 13. (6, 6) R (6, 6) | |

× 2

Total 24 + 1 = 25

(Held On Tuesday 09th April, 2024)
TIME : 9 : 00 AM to 12 : 00 NOON

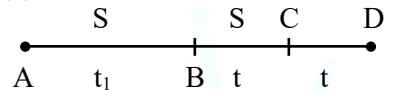
PHYSICS	TEST PAPER WITH SOLUTION
SECTION-A	
<p>31. A proton, an electron and an alpha particle have the same energies. Their de-Broglie wavelengths will be compared as:</p> <p>(1) $\lambda_e > \lambda_\alpha > \lambda_p$ (2) $\lambda_\alpha < \lambda_p < \lambda_e$ (3) $\lambda_p < \lambda_e < \lambda_\alpha$ (4) $\lambda_p > \lambda_e > \lambda_\alpha$</p> <p>Ans. (2)</p> <p>Sol. $\lambda_{DB} = \frac{h}{p} = \frac{h}{\sqrt{2mk}}$ $\Rightarrow \lambda_{DB} \propto \frac{1}{\sqrt{m}}$ $\Rightarrow \lambda_\alpha < \lambda_p < \lambda_e$</p> <p>32. A particle moving in a straight line covers half the distance with speed 6 m/s. The other half is covered in two equal time intervals with speeds 9 m/s and 15 m/s respectively. The average speed of the particle during the motion is :</p> <p>(1) 8.8 m/s (2) 10 m/s (3) 9.2 m/s (4) 8 m/s</p> <p>Ans. (4)</p> <p>Sol.  $BD \Rightarrow S = 9t + 15t = 24t$ $AB \Rightarrow S = 6t_1 = 24t \Rightarrow t_1 = 4t$ $\langle \text{speed} \rangle = \frac{\text{dist.}}{\text{time}} = \frac{48t}{2t + t_1}$ $= \frac{48t}{2t + 4t} \Rightarrow \frac{48t}{6t} \Rightarrow 8 \text{ m/s}$</p> <p>33. A plane EM wave is propagating along x direction. It has a wavelength of 4 mm. If electric field is in y direction with the maximum magnitude of 60 Vm^{-1}, the equation for magnetic field is:</p> <p>(1) $B_z = 60 \sin \left[\frac{\pi}{2} (x - 3 \times 10^8 t) \right] \hat{k} \text{T}$ (2) $B_z = 2 \times 10^{-7} \sin \left[\frac{\pi}{2} \times 10^3 (x - 3 \times 10^8 t) \right] \hat{k} \text{T}$ (3) $B_x = 60 \sin \left[\frac{\pi}{2} (x - 3 \times 10^8 t) \right] \hat{i} \text{T}$ (4) $B_z = 2 \times 10^{-7} \sin \left[\frac{\pi}{2} (x - 3 \times 10^8 t) \right] \hat{k} \text{T}$</p> <p>Ans. (2)</p> <p>Sol. $E = BC \Rightarrow 60 = B \times 3 \times 10^8$</p>	$\Rightarrow B = 2 \times 10^{-7}$ Also $C = f\lambda$ $\Rightarrow 3 \times 10^8 = f \times 4 \times 10^{-3}$ $\Rightarrow f = \frac{3}{4} \times 10^{11}$ $\Rightarrow \omega = 2\pi f = \frac{3}{4} \times 2\pi \times 10^{11}$ $\Rightarrow \omega = \frac{\pi}{2} \times 10^3 \text{ C}$ \Rightarrow Electric field \Rightarrow y direction Propagation \Rightarrow x direction Magnetic field \Rightarrow z-direction
<p>34. Given below are two statements:</p> <p>Statement (I): When an object is placed at the centre of curvature of a concave lens, image is formed at the centre of curvature of the lens on the other side.</p> <p>Statement (II): Concave lens always forms a virtual and erect image.</p> <p>In the light of the above statements, choose the correct answer from the options given below:</p> <p>(1) Statement I is false but Statement II is true. (2) Both Statement I and Statement II are false. (3) Statement I is true but Statement II is false. (4) Both Statement I and Statement II are true.</p> <p>NTA Ans. (1)</p> <p>Ans. (2)</p> <p>Sol. $\frac{1}{v} - \frac{1}{u} = \frac{1}{f}$ $\frac{1}{v} - \frac{1}{-2f} = \frac{1}{-f}$ $\Rightarrow \frac{1}{v} = \frac{-1}{2f} \Rightarrow v = -2f$ $\frac{1}{v} = \frac{1}{u} + \frac{1}{f} \Rightarrow$ Virtual image of Real object.</p> <p>In statement II, it is not mentioned that object is real or virtual hence Statement II is false.</p>	



35. A light emitting diode (LED) is fabricated using GaAs semiconducting material whose band gap is 1.42 eV. The wavelength of light emitted from the LED is:

- (1) 650 nm (2) 1243 nm
(3) 875 nm (4) 1400 nm

Ans. (3)

Sol. $\lambda = \frac{1240}{1.42} = 875 \text{ nm (Approx)}$

36. A sphere of relative density σ and diameter D has concentric cavity of diameter d . The ratio of $\frac{D}{d}$, if it just floats on water in a tank is:

- (1) $\left(\frac{\sigma}{\sigma-1}\right)^{\frac{1}{3}}$ (2) $\left(\frac{\sigma+1}{\sigma-1}\right)^{\frac{1}{3}}$
(3) $\left(\frac{\sigma-1}{\sigma}\right)^{\frac{1}{3}}$ (4) $\left(\frac{\sigma-2}{\sigma+2}\right)^{\frac{1}{3}}$

Ans. (1)

Sol. weight (w) = $\frac{4}{3}\pi\left(\frac{D^3-d^3}{8}\right)\sigma g$

Buoyant force (F_b) = $1 \times \frac{4}{3}\pi\left(\frac{D^3}{8}\right) \cdot g$

For Just Float $\Rightarrow w = F_b$

$\Rightarrow (D^3 - d^3)\sigma = D^3$

$\Rightarrow 1 - \frac{d^3}{D^3} = \frac{1}{\sigma}$

$\Rightarrow 1 - \frac{1}{\sigma} = \left(\frac{d}{D}\right)^3$

$\Rightarrow \left(\frac{\sigma}{\sigma-1}\right)^{\frac{1}{3}} = \left(\frac{D}{d}\right)$

37. A capacitor is made of a flat plate of area A and a second plate having a stair-like structure as shown in figure. If the area of each stair is $\frac{A}{3}$ and the height is d , the capacitance of the arrangement is:

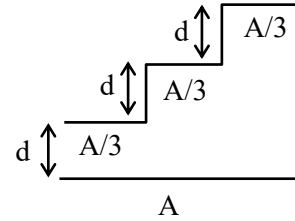

- (1) $\frac{11\epsilon_0 A}{18d}$ (2) $\frac{13\epsilon_0 A}{17d}$
(3) $\frac{11\epsilon_0 A}{20d}$ (4) $\frac{18\epsilon_0 A}{11d}$

Ans. (1)

Sol. All capacitor are in parallel combination.

Also effective area is common area only

$\Rightarrow C_{eq} = C_1 + C_2 + C_3$

$\Rightarrow C_{eq} = \frac{A\epsilon_0}{3d} + \frac{A\epsilon_0}{3(2d)} + \frac{A\epsilon_0}{3(3d)}$

$\Rightarrow C_{eq} = \frac{A\epsilon_0}{3} \left(\frac{11}{6d}\right)$

$\Rightarrow C_{eq} = \frac{11A\epsilon_0}{18d}$

38. A light unstretchable string passing over a smooth light pulley connects two blocks of masses m_1 and m_2 . If the acceleration of the system is $\frac{g}{8}$, then the

ratio of the masses $\frac{m_2}{m_1}$ is:

- (1) 9 : 7 (2) 4 : 3
(3) 5 : 3 (4) 8 : 1

Ans. (1)

Sol. $a_{sys} = \left(\frac{m_2 - m_1}{m_1 + m_2}\right)g = \frac{g}{8}$

$\Rightarrow \frac{m_2}{m_1} = \frac{9}{7}$

39. The dimensional formula of latent heat is:

- (1) $[M^0L^2T^{-2}]$ (2) $[MLT^{-2}]$
 (3) $[M^0L^2T^{-2}]$ (4) $[ML^2T^{-2}]$

Ans. (3)

Sol. Latent heat is specific heat

$$\Rightarrow \frac{ML^2T^{-2}}{M} = M^0L^2T^{-2}$$

40. The volume of an ideal gas ($\gamma = 1.5$) is changed adiabatically from 5 litres to 4 litres. The ratio of initial pressure to final pressure is:

- (1) $\frac{4}{5}$ (2) $\frac{16}{25}$
 (3) $\frac{8}{5\sqrt{5}}$ (4) $\frac{2}{\sqrt{5}}$

Ans. (3)

Sol. For Adiabatic process

$$P_i V_i = P_f V_f^\gamma$$

$$P_i (5)^{1.5} = P_f (4)^{1.5}$$

$$\frac{P_i}{P_f} = \left(\frac{4}{5}\right)^{\frac{3}{2}} = \frac{4}{5} \cdot \left(\frac{4}{5}\right)^{\frac{1}{2}} \Rightarrow \frac{8}{5\sqrt{5}}$$

41. The energy equivalent of 1g of substance is:

- (1) 11.2×10^{24} MeV (2) 5.6×10^{12} MeV
 (3) 5.6 eV (4) 5.6×10^{26} MeV

Ans. (4)

Sol. $E = mC^2$

$$\Rightarrow E = (1 \times 10^{-3}) \times (3 \times 10^8)^2 \text{ J}$$

$$\Rightarrow E = (10^{-3}) (9 \times 10^{16}) (6.241 \times 10^{18}) \text{ eV}$$

$$E = 56.169 \times 10^{31} \text{ eV}$$

$$E \approx 5.6 \times 10^{26} \text{ MeV}$$

42. An astronaut takes a ball of mass m from earth to space. He throws the ball into a circular orbit about earth at an altitude of 318.5 km. From earth's surface to the orbit, the change in total mechanical

energy of the ball is $x \frac{GM_e m}{21R_e}$. The value of x is

(take $R_e = 6370$ km):

- (1) 11 (2) 9
 (3) 12 (4) 10

Ans. (1)

Sol. $h = 318.5 \approx \left(\frac{R_e}{20}\right)$

$$T \cdot E_i = \frac{-GM_e m}{R_e}$$

$$T \cdot E_f = \frac{-GM_e m}{2(R_e + h)} = \frac{-GM_e m}{2\left(R_e + \frac{R_e}{20}\right)}$$

$$\Rightarrow T \cdot E_f = \frac{-10GM_e m}{21R_e}$$

Change in total mechanical energy

$$= TE_f - TE_i$$

$$= \frac{GM_e m}{R_e} \left[1 - \frac{10}{21}\right] = \frac{11GM_e m}{21R_e}$$

43. Given below are two statements:

Statement (I) : When currents vary with time, Newton's third law is valid only if momentum carried by the electromagnetic field is taken into account.

Statement (II) : Ampere's circuital law does not depend on Biot-Savart's law.

In the light of the above statements, choose the **correct** answer from the options given below:

- (1) Both **Statement I** and **Statement II** are false.
 (2) **Statement I** is true but **Statement II** is false.
 (3) **Statement I** is false but **Statement II** is true.
 (4) Both **Statement I** and **Statement II** are true.

Ans. (2)

Sol. Conceptual.

44. A particle of mass m moves on a straight line with its velocity increasing with distance according to the equation $v = \alpha\sqrt{x}$, where α is a constant. The total work done by all the forces applied on the particle during its displacement from $x = 0$ to $x = d$, will be:

- (1) $\frac{m}{2\alpha^2 d}$ (2) $\frac{md}{2\alpha^2}$
 (3) $\frac{m\alpha^2 d}{2}$ (4) $2m\alpha^2 d$

Ans. (3)

Sol. $v = \alpha\sqrt{x}$
 at $x = 0 : v = 0$
 & at $x = d ; v = \alpha\sqrt{d}$
 $W.D = K_f - K_i$
 $W.D = \frac{1}{2}m(\alpha\sqrt{d})^2 - \frac{1}{2}m(0)^2$
 $\Rightarrow W.D = \frac{m\alpha^2 d}{2}$

45. A galvanmeter has a coil of resistance 200Ω with a full scale deflection at $20 \mu A$. The value of resistance to be added to use it as an ammeter of range $(0-20) \text{ mA}$ is:

- (1) 0.40Ω (2) 0.20Ω
 (3) 0.50Ω (4) 0.10Ω

Ans. (2)

Sol. $G = 200 \Omega$
 $i_g = 20 \mu A$
 $i = i_g \left(\frac{G}{S} + 1 \right)$
 $\Rightarrow 20 \times 10^{-3} = 20 \times 10^{-6} \left(\frac{200}{S} + 1 \right)$
 $\Rightarrow \frac{200}{S} = 999$
 $\Rightarrow S \approx 0.2 \Omega$

46. A heavy iron bar, of weight W is having its one end on the ground and the other on the shoulder of a person. The bar makes an angle θ with the horizontal. The weight experienced by the person is:

- (1) $\frac{W}{2}$ (2) W
 (3) $W \cos \theta$ (4) $W \sin \theta$

Ans. (1)

Sol.

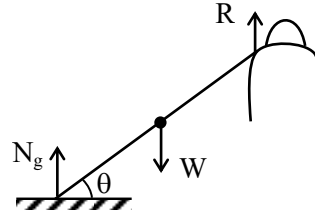

$R =$ net reaction force by shoulder

Balancing torque about pt of contact on ground:

$$W \left(\frac{L}{2} \cos \theta \right) = R (L \cos \theta)$$

$$\Rightarrow R = \frac{W}{2}$$

47. One main scale division of a vernier caliper is equal to m units. If n^{th} division of main scale coincides with $(n + 1)^{\text{th}}$ division of vernier scale, the least count of the vernier caliper is:

- (1) $\frac{n}{(n+1)}$ (2) $\frac{m}{(n+1)}$
 (3) $\frac{1}{(n+1)}$ (4) $\frac{m}{n(n+1)}$

Ans. (2)

Sol. $n \text{ MSD} = (n + 1) \text{ VSD}$
 $\Rightarrow 1 \text{ VSD} = \frac{n}{n+1} \text{ MSD}$
 $L.C = 1 \text{ MSD} - 1 \text{ VSD}$
 $L.C = m - m \left(\frac{n}{n+1} \right)$
 $L.C = m \left(\frac{n+1-n}{n+1} \right)$
 $\Rightarrow L.C = \left(\frac{m}{n+1} \right)$

48. A bulb and a capacitor are connected in series across an ac supply. A dielectric is then placed between the plates of the capacitor. The glow of the bulb:

- (1) increases (2) remains same
 (3) becomes zero (4) decreases

Ans. (1)

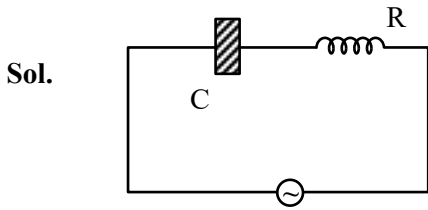

$$Z = \sqrt{R^2 + X_C^2} \text{ \& } X_C = \frac{1}{\omega C}$$

due to dielectric

$$C \uparrow \Rightarrow X_C \downarrow \Rightarrow Z \downarrow$$

So, current increases & thus bulb will glow more brighter.

49. The equivalent resistance between A and B is:

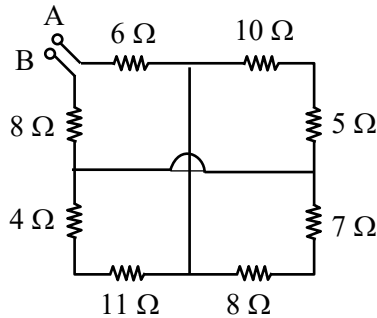

- (1) 18 Ω (2) 25 Ω
 (3) 27 Ω (4) 19 Ω

Ans. (4)

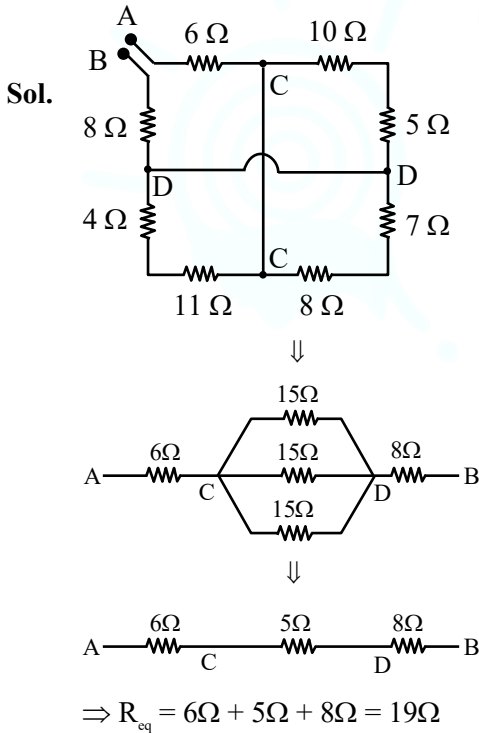

50. A sample of 1 mole gas at temperature T is adiabatically expanded to double its volume. If adiabatic constant for the gas is $\gamma = \frac{3}{2}$, then the work done by the gas in the process is:

- (1) $RT[2 - \sqrt{2}]$ (2) $\frac{R}{T}[2 - \sqrt{2}]$
 (3) $RT[2 + \sqrt{2}]$ (4) $\frac{T}{R}[2 + \sqrt{2}]$

Ans. (1)

Sol. $TV^{\gamma-1} = \text{constant}$

$$\Rightarrow T(V)^{\frac{3}{2}-1} = T_f(2V)^{\frac{3}{2}-1}$$

$$\Rightarrow TV^{\frac{1}{2}} = T_f(2)^{\frac{1}{2}}(V)^{\frac{1}{2}}$$

$$\Rightarrow T_f = \left(\frac{T}{\sqrt{2}}\right)$$

$$\text{Now, W.D.} = \frac{nR\Delta T}{1-\gamma} = \frac{1 \cdot R \left[\frac{T}{\sqrt{2}} - T \right]}{1 - \frac{3}{2}}$$

$$\Rightarrow \text{W.D.} = 2RT \left[1 - \frac{1}{\sqrt{2}} \right]$$

$$\Rightarrow \text{W.D.} = RT[2 - \sqrt{2}]$$

SECTION-B

51. If \vec{a} and \vec{b} makes an angle $\cos^{-1}\left(\frac{5}{9}\right)$ with each other, then $|\vec{a} + \vec{b}| = \sqrt{2} |\vec{a} - \vec{b}|$ for $|\vec{a}| = n |\vec{b}|$. The integer value of n is _____.

Ans. (3)

Sol. $\cos\theta = \frac{5}{9}$

$$\frac{\vec{a} \cdot \vec{b}}{ab} = \frac{5}{9} \dots\dots(1)$$

$$|\vec{a} + \vec{b}| = \sqrt{2} |\vec{a} - \vec{b}|$$

$$a^2 + b^2 + 2\vec{a} \cdot \vec{b} = 2a^2 + 2b^2 - 4\vec{a} \cdot \vec{b}$$

$$6\vec{a} \cdot \vec{b} = a^2 + b^2$$

$$6 \times \frac{5}{9} ab = a^2 + b^2$$

$$\frac{10}{3} ab = a^2 + b^2 \quad \& \quad a = nb$$

$$\frac{10}{3} nb^2 = n^2 b^2 + b^2$$

$$3n^2 - 10n + 3 = 0$$

$$n = \frac{1}{3} \quad \text{and} \quad n = 3$$

integer value $n = 3$

- 52.** At the centre of a half ring of radius $R = 10$ cm and linear charge density $4n$ C m^{-1} , the potential is $x \pi$ V. The value of x is _____.

Ans. (36)

Sol. Potential at centre of half ring

$$V = \frac{KQ}{R}$$

$$V = \frac{K\lambda\pi R}{R}$$

$$V = K\lambda\pi \Rightarrow V = 9 \times 10^9 \times 4 \times 10^{-9} \pi$$

$$V = 36\pi$$

- 53.** A star has 100% helium composition. It starts to convert three ${}^4\text{He}$ into one ${}^{12}\text{C}$ via triple alpha process as ${}^4\text{He} + {}^4\text{He} + {}^4\text{He} \rightarrow {}^{12}\text{C} + Q$. The mass of the star is 2.0×10^{32} kg and it generates energy at the rate of 5.808×10^{30} W. The rate of converting these ${}^4\text{He}$ to ${}^{12}\text{C}$ is $n \times 10^{42} \text{ s}^{-1}$, where n is _____. [Take, mass of ${}^4\text{He} = 4.0026$ u, mass of ${}^{12}\text{C} = 12$ u]

NTA Ans. (5)

Ans. (15)

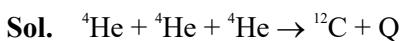

$$\text{power generated} = \frac{N}{t} Q$$

where, $N \rightarrow$ No. of reaction/sec.

$$Q = (3m_{\text{He}} - m_{\text{C}}) C^2$$

$$Q = (3 \times 4.0026 - 12) (3 \times 10^8)^2$$

$$Q = 7.266 \text{ MeV}$$

$$\frac{N}{t} = \frac{\text{power}}{Q} = \frac{5.808 \times 10^{30}}{7.266 \times 10^6 \times 1.6 \times 10^{-19}}$$

$$\frac{N}{t} = 5 \times 10^{42}$$

rate of conversion of ${}^4\text{He}$ into ${}^{12}\text{C} = 15 \times 10^{42}$

Hence, $n = 15$

- 54.** In a Young's double slit experiment, the intensity at a point is $\left(\frac{1}{4}\right)^{\text{th}}$ of the maximum intensity, the minimum distance of the point from the central maximum is _____ μm . (Given : $\lambda = 600$ nm, $d = 1.0$ mm, $D = 1.0$ m)

Ans. (200)

Sol. $I = I_0 \cos^2\left(\frac{\Delta\phi}{2}\right)$

$$\frac{I_0}{4} = \cos^2\left(\frac{\Delta\phi}{2}\right)$$

$$\Delta\phi = \frac{2\pi}{3}$$

$$\frac{2\pi}{\lambda} \left(\frac{yd}{D}\right) = \frac{2\pi}{3}$$

$$y = \frac{\lambda D}{3d} = \frac{600 \times 10^{-9} \times 1}{3 \times 10^{-3}} = 2 \times 10^{-4} \text{ m}$$

- 55.** A string is wrapped around the rim of a wheel of moment of inertia 0.40 kgm^2 and radius 10 cm. The wheel is free to rotate about its axis. Initially the wheel is at rest. The string is now pulled by a force of 40 N. The angular velocity of the wheel after 10 s is x rad/s, where x is _____.

Ans. (100)

Sol. $\tau = FR = I\alpha \Rightarrow 40 \times 0.1 = 0.4\alpha$

$$\alpha = 10 \text{ rad/s}^2$$

$$W_f = 10 \times 10 = 100 \text{ rad/s}$$

- 56.** A square loop of edge length 2 m carrying current of 2 A is placed with its edges parallel to the x - y axis. A magnetic field is passing through the x - y plane and expressed as $\vec{B} = B_0(1+4x)\hat{k}$, where $B_0 = 5$ T. The net magnetic force experienced by the loop is _____ N.

Ans. (160)

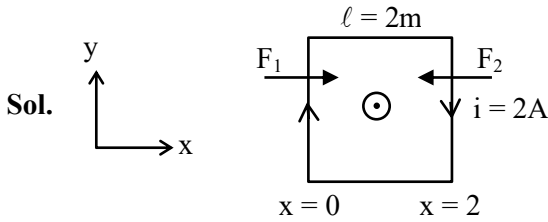

$B(x=0) = B_0, \quad B(x=2) = 9B_0$
 Also, $F = i\ell B$
 $\Rightarrow F_1 = i\ell B_0 \quad \& \quad F_2 = 9i\ell B_0$
 $F = F_2 - F_1 = 8i\ell B_0 = 8 \times 2 \times 2 \times 5$
 $F = 160 \text{ N}$

57. Two persons pull a wire towards themselves. Each person exerts a force of 200 N on the wire. Young's modulus of the material of wire is $1 \times 10^{11} \text{ N m}^{-2}$. Original length of the wire is 2 m and the area of cross section is 2 cm^2 . The wire will extend in length by _____ μm .

Ans. (20)



$\frac{F}{A} = Y \frac{\Delta \ell}{\ell} \Rightarrow \Delta \ell = \frac{F\ell}{AY}$
 $\Delta \ell = \frac{200 \times 2}{2 \times 10^{-4} \times 10^{11}} = 2 \times 10^{-5} = 20 \mu\text{m}$

58. When a coil is connected across a 20 V dc supply, it draws a current of 5 A. When it is connected across 20 V, 50 Hz ac supply, it draws a current of 4 A. The self inductance of the coil is _____ mH. (Take $\pi = 3$)

Ans. (10)

Sol. Case-I:

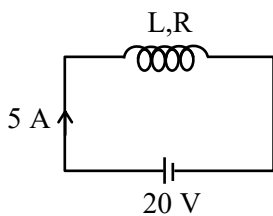

$i = \frac{20}{R} \Rightarrow R = 4\Omega$

Case-II:

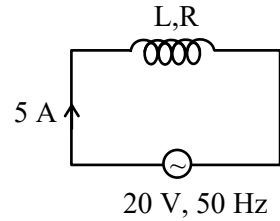

$i = \frac{20}{Z}$
 $4 = \frac{20}{\sqrt{R^2 + X_L^2}} \Rightarrow \sqrt{R^2 + X_L^2} = 5$
 $R^2 + X_L^2 = 25 \Rightarrow X_L = 3 \Omega$
 $L = \frac{3}{2\pi f} = \frac{1}{2 \times 50} = \frac{1000}{100} \text{ mH}$
 $L = 10 \text{ mH}$

59. The position, velocity and acceleration of a particle executing simple harmonic motion are found to have magnitudes of 4 m, 2 ms^{-1} and 16 ms^{-2} at a certain instant. The amplitude of the motion is \sqrt{x} m where x is _____.

Ans. (17)

Sol. $x = 4 \text{ m}, V = 2 \text{ m/s}, a = 16 \text{ m/s}^2$

$|a| = \omega^2 x$
 $\Rightarrow 16 = \omega^2(4)$
 $\omega = 2 \text{ rad/s}$
 $v = \omega \sqrt{A^2 - x^2}$

$A = \sqrt{\frac{v^2}{\omega^2} + x^2} \Rightarrow A = \sqrt{\frac{4}{4} + 16}$

$A = \sqrt{17} \text{ m}$

60. The current flowing through the 1Ω resistor is $\frac{n}{10}$

A. The value of n is _____.

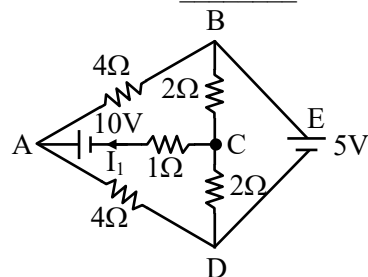

Ans. (25)

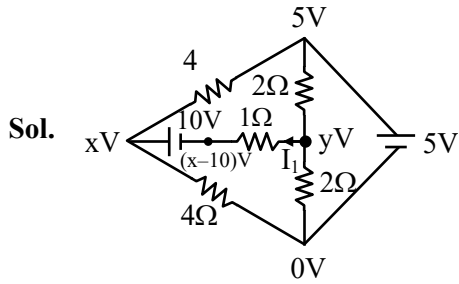

$$\frac{y-5}{2} + \frac{y-0}{2} + \frac{y-x+10}{1} = 0$$

$$y-5+y+2y-2x+20=0$$

$$4y-2x+15=0 \quad \dots(i)$$

$$\frac{x-5}{4} + \frac{x-0}{4} + \frac{x-10-y}{1} = 0$$

$$x-5+x+4x-40-4y=0$$

$$6x-4y-45=0 \quad \dots(ii)$$

$$-2x+4y+15=0 \quad \dots(iii)$$

$$4x-30=0$$

$$x = \frac{15}{2} \quad \& \quad 4y - 15 + 15 = 0$$

$$y = 0$$

$$i = \frac{y-x+10}{1}$$

$$i = \frac{0 - 7.5 + 10}{1}$$

$$i = 2.5A = \frac{n}{10}A$$

$$n = 25$$

(Held On Tuesday 09th April, 2024)

TIME : 9 : 00 AM to 12 : 00 NOON

CHEMISTRY
SECTION-A

61. The molar conductivity for electrolytes A and B are plotted against $C^{1/2}$ as shown below. Electrolytes A and B respectively are :

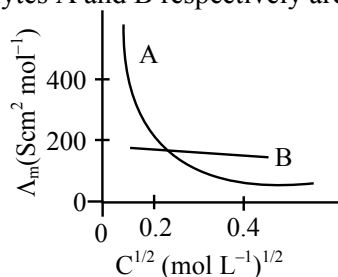
A
B

- | | |
|------------------------|--------------------|
| (1) Weak electrolyte | weak electrolyte |
| (2) Strong electrolyte | strong electrolyte |
| (3) Weak electrolyte | strong electrolyte |
| (4) Strong electrolyte | weak electrolyte |

Ans. (3)

Sol. A → Weak electrolyte
B → Strong electrolyte

62. Methods used for purification of organic compounds are based on :
- (1) neither on nature of compound nor on the impurity present.
 - (2) nature of compound only.
 - (3) nature of compound and presence of impurity.
 - (4) presence of impurity only.

Ans. (3)

Sol. Organic compounds are purified based on their nature and impurity present in it.

63. In the following sequence of reaction, the major products B and C respectively are :

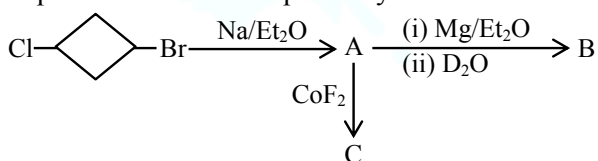

- (1) D-Cyclohexane-D and F-Cyclohexane-F
- (2) D-Cyclohexane-D and F-Cyclohexane-F
- (3) D-Cyclohexane-D and F-Cyclohexane-F
- (4) D-Cyclohexane-D and F-Cyclohexane-F

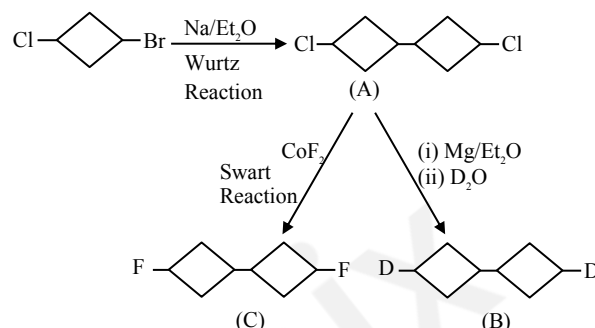
Ans. (1)
TEST PAPER WITH SOLUTION
Sol.

64.

Correct order of basic strength of Pyrrole

Pyridine and Piperidine is:

- (1) Piperidine > Pyridine > Pyrrole
- (2) Pyrrole > Pyridine > Piperidine
- (3) Pyridine > Piperidine > Pyrrole
- (4) Pyrrole > Piperidine > Pyridine

Ans. (1)

Sol. Order of basic strength is
 $N(sp^3, \text{ localized lone pair}) > N(sp^2, \text{ localized lone pair}) > N(sp^2, \text{ delocalized lone pair, aromatic})$
 \therefore Piperidine > Pyridine > Pyrrole

65. In which one of the following pairs the central atoms exhibit sp^2 hybridization ?

- (1) BF_3 and NO_2^-
- (2) NH_2^- and H_2O
- (3) H_2O and NO_2
- (4) NH_2^- and BF_3

Ans. (1)

Sol. $\text{BF}_3 \rightarrow sp^2$
 $\text{NO}_2^- \rightarrow sp^2$
 $\text{H}_2\text{O} \rightarrow sp^3$
 $\text{NO}_2 \rightarrow sp^2$
 $\text{NH}_2^- \rightarrow sp^3$

66. The F^- ions make the enamel on teeth much harder by converting hydroxyapatite (the enamel on the surface of teeth) into much harder fluoroapatite having the formula.

- (1) $[3(Ca_3(PO_4)_2) \cdot CaF_2]$
- (2) $[3(Ca_2(PO_4)_2) \cdot Ca(OH)_2]$
- (3) $[3(Ca_3(PO_4)_3) \cdot CaF_2]$
- (4) $[3(Ca_3(PO_4)_2) \cdot Ca(OH)_2]$

Ans. (1)

Sol. Fluoroapatite $\Rightarrow [3Ca_3(PO_4)_2 \cdot CaF_2]$

67. Relative stability of the contributing structures is :

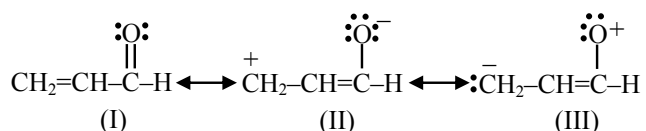

- (1) (I) > (III) > (II)
- (2) (I) > (II) > (III)
- (3) (II) > (I) > (III)
- (4) (III) > (II) > (I)

Ans. (2)

Sol. (1) Neutral structures are more stable than charged ones. Therefore I is more stable than II and III.

(2) +ve charge on less electronegative atom is more stable i.e., C^\oplus is more stable than O^\oplus

\therefore Order is I > II > III

68. Given below are two statements :

Statement (I) : The oxidation state of an element in a particular compound is the charge acquired by its atom on the basis of electron gain enthalpy consideration from other atoms in the molecule.

Statement (II) : $p\pi-p\pi$ bond formation is more prevalent in second period elements over other periods.

In the light of the above statements, choose the **most appropriate** answer from the options given below :

- (1) Both **Statement I** and **Statement II** are incorrect
- (2) **Statement I** is correct but **Statement II** is incorrect
- (3) Both **Statement I** and **Statement II** are correct
- (4) **Statement I** is incorrect but **Statement II** is correct

Ans. (4)

Sol. Oxidation state of an element in a particular compound is defined by the charge acquired by its atom on the basis of electronegativity consideration from other atoms in molecule.

69. Given below are two statements : one is labelled as **Assertion (A)** and the other is labelled as **Reason (R)** :

Assertion (A) : S_N2 reaction of $C_6H_5CH_2Br$ occurs more readily than the S_N2 reaction of CH_3CH_2Br .

Reason (R) : The partially bonded unhybridized p-orbital that develops in the trigonal bipyramidal transition state is stabilized by conjugation with the phenyl ring.

In the light of the above statements, choose the **most appropriate** answer from the options given below :

- (1) **(A)** is not correct but **(R)** is correct
- (2) Both **(A)** and **(R)** are correct but **(R)** is not the correct explanation of **(A)**
- (3) Both **(A)** and **(R)** are correct and **(R)** is the correct explanation of **(A)**
- (4) **(A)** is correct but **(R)** is not correct

Ans. (3)

Sol. The benzyl group acts in much the same way using the π -system of the benzene ring for conjugation with the p-orbital in the transition state.

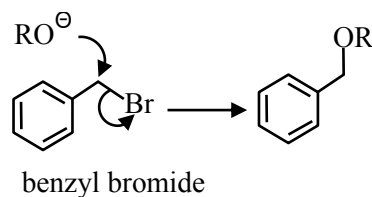

70. For the given compounds, the correct order of increasing pK_a value :

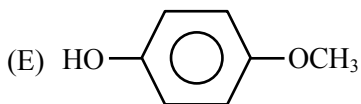
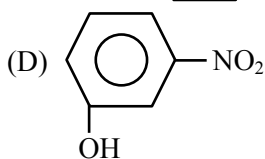
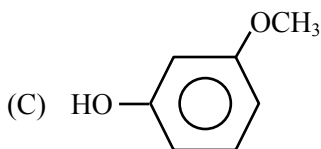
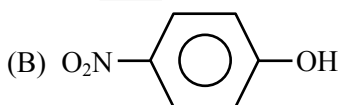
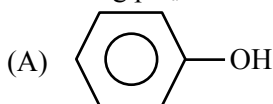

- (1) (E) < (D) < (C) < (B) < (A)
 (2) (D) < (E) < (C) < (B) < (A)
 (3) (E) < (D) < (B) < (A) < (C)
 (4) (B) < (D) < (A) < (C) < (E)

Ans. **BONUS**

NTA Ans. (4)

Sol. Acidic strength order :-

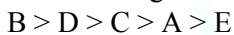

Correct pK_a Order :

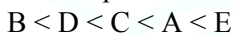

All options are incorrect.

71. Given below are two statements : one is labelled as **Assertion (A)** : and the other is labelled as **Reason (R)**.

Assertion (A) : Both rhombic and monoclinic sulphur exist as S_8 while oxygen exists as O_2 .

Reason (R) : Oxygen forms $p\pi-p\pi$ multiple bonds with itself and other elements having small size and high electronegativity like C, N, which is not possible for sulphur.

In the light of the above statements, choose the **most appropriate** answer from the options given below :

- (1) Both (A) and (R) are correct and (R) is the correct explanation of (A).
 (2) Both (A) and (R) are correct but (R) is not the correct explanation of (A).
 (3) (A) is correct but (R) is not correct.
 (4) (A) is not correct but (R) is correct.

Ans. (3)

Sol. Oxygen can form $2p\pi-2p\pi$ multiple bond with itself due to its small size while sulphur cannot form multiple bond with itself as $3p\pi-3p\pi$ bond will be unstable due to large size of sulphur, but sulphur can form multiple bond with small size atom like C and N.

eg. $S=C=S$

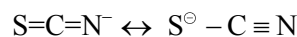

72. Given below are two statements : one is labelled as **Assertion (A)** and the other is labelled as **Reason (R)**.

Assertion (A): The total number of geometrical isomers shown by $[Co(en)_2Cl_2]^+$ complex ion is three

Reason (R): $[Co(en)_2Cl_2]^+$ complex ion has an octahedral geometry.

In the light of the above statements, choose the **most appropriate** answer from the options given below :

- (1) Both (A) and (R) are correct and (R) is the correct explanation of (A).
 (2) (A) is correct but (R) is not correct.
 (3) (A) is not correct but (R) is correct.
 (4) Both (A) and (R) are correct but (R) is not the correct explanation of (A).

Ans. (3)

Sol. $[Co(en)_2Cl_2]^+$ has octahedral geometry with two geometrical isomers.

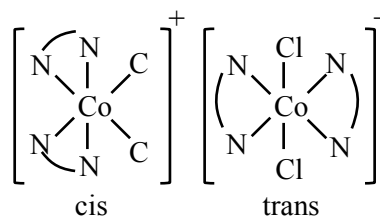

73. The electronic configuration of Cu(II) is $3d^9$ whereas that of Cu(I) is $3d^{10}$. Which of the following is correct ?

- (1) Cu(II) is less stable
 (2) Stability of Cu(I) and Cu(II) depends on nature of copper salts
 (3) Cu(II) is more stable
 (4) Cu(I) and Cu(II) are equally stable

Ans. (3)

Sol. Cu(II) is more stable than Cu(I) because hydration energy of Cu^{+2} ion compensate IE_2 of Cu.

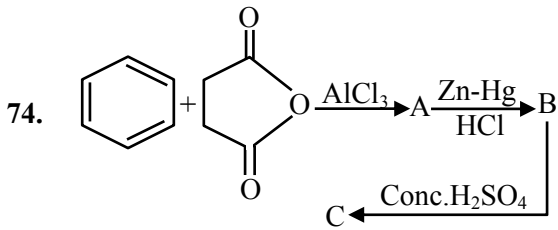

What is the structure of C ?

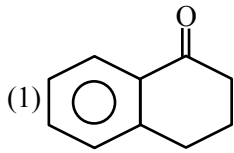
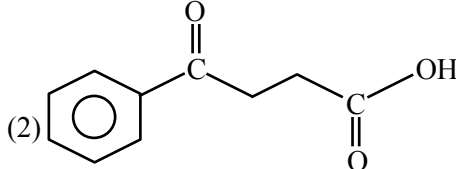
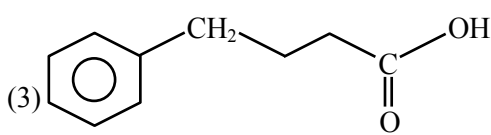
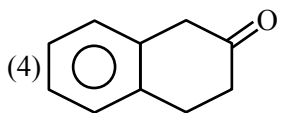
- (1) 
- (2) 
- (3) 
- (4) 

Ans. (1)

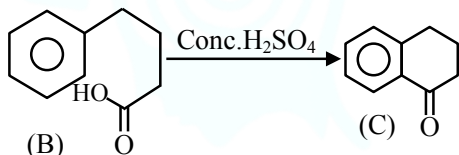
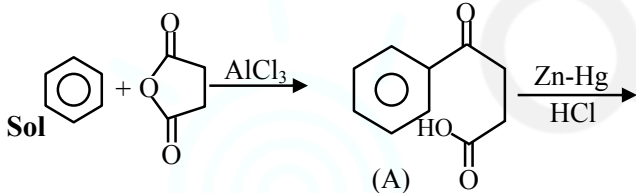

75. Compare the energies of following sets of quantum numbers for multielectron system.

- (A) $n = 4, l = 1$ (B) $n = 4, l = 2$
 (C) $n = 3, l = 1$ (D) $n = 3, l = 2$
 (E) $n = 4, l = 0$

Choose the correct answer from the options given below :

- (1) (B) > (A) > (C) > (E) > (D)
 (2) (E) > (C) < (D) < (A) < (B)
 (3) (E) > (C) > (A) > (D) > (B)
 (4) (C) < (E) < (D) < (A) < (B)

Ans. (4)

Sol. Energy level can be determined by comparing $(n + \ell)$ values

- (A) $n = 4, \ell = 1 \Rightarrow (n + \ell) = 5$
 (B) $n = 4, \ell = 2 \Rightarrow (n + \ell) = 6$
 (C) $n = 3, \ell = 1 \Rightarrow (n + \ell) = 4$
 (D) $n = 3, \ell = 2 \Rightarrow (n + \ell) = 5$
 (E) $n = 4, \ell = 0 \Rightarrow (n + \ell) = 4$

For same value of $(n + \ell)$, orbital having higher value of n , will have more energy.

(B) > (A) > (D) > (E) > (C)

76. Identify major product "X" formed in the following reaction :

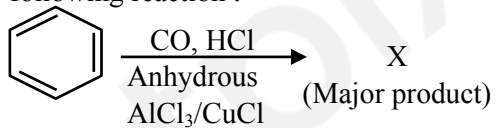

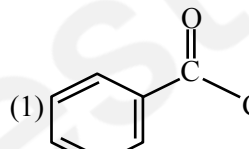
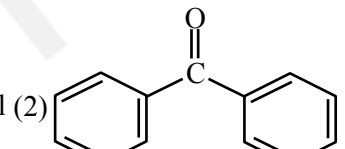
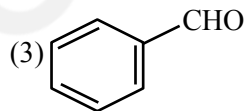
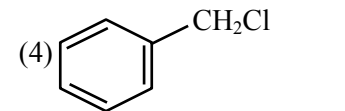
- (1)  (2) 
 (3)  (4) 

Ans. (3)

Sol. This is Gattermann-Koch reaction

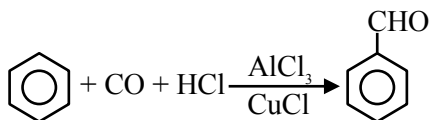

77. Identify the product A and product B in the following set of reactions.

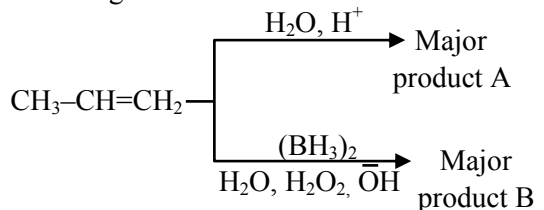

- (1) A- $\text{CH}_3\text{CH}_2\text{CH}_2\text{-OH}$, B- $\text{CH}_3\text{CH}_2\text{CH}_2\text{-OH}$
 (2) A- $\text{CH}_3\text{CH}_2\text{CH}_2\text{-OH}$, B- $\text{CH}_3\text{CH(OH)CH}_3$
 (3) A- $\text{CH}_3\text{-CH(OH)-CH}_3$, B- $\text{CH}_3\text{CH}_2\text{CH}_2\text{-OH}$
 (4) A- $\text{CH}_3\text{CH}_2\text{CH}_3$, B- $\text{CH}_3\text{CH}_2\text{CH}_3$

Ans. (3)

Sol. (1) Hydration Reaction :

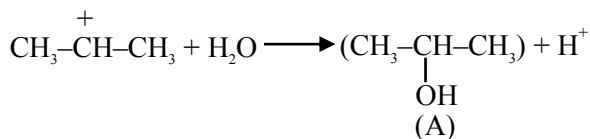
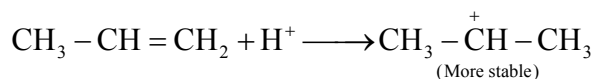

(2) Hydroboration Oxidation Reaction :

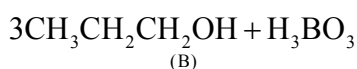
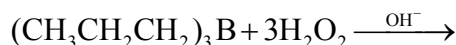
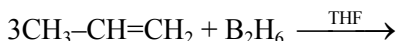

78. On reaction of Lead Sulphide with dilute nitric acid which of the following is **not** formed ?

- (1) Lead nitrate (2) Sulphur
(3) Nitric oxide (4) Nitrous oxide

Ans. (4)

Sol. $\text{PbS} + \text{HNO}_3 \rightarrow \text{Pb}(\text{NO}_3)_2 + \text{NO} + \text{S} + \text{H}_2\text{O}$

Nitrous oxide (N_2O) is not formed during the reaction.

79. Identify the **incorrect** statements regarding primary standard of titrimetric analysis

- (A) It should be purely available in dry form.
(B) It should not undergo chemical change in air.
(C) It should be hygroscopic and should react with another chemical instantaneously and stoichiometrically.
(D) It should be readily soluble in water.
(E) KMnO_4 & NaOH can be used as primary standard.

Choose the **correct** answer from the options given below :

- (1) (C) and (D) only (2) (B) and (E) only
(3) (A) and (B) only (4) (C) and (E) only

Ans. (4)

Sol. KMnO_4 & $\text{NaOH} \rightarrow$ Secondary standard.

Primary standard should not be Hygroscopic.

80. 0.05M CuSO_4 when treated with 0.01M $\text{K}_2\text{Cr}_2\text{O}_7$ gives green colour solution of $\text{Cu}_2\text{Cr}_2\text{O}_7$. The [SPM : Semi Permeable Membrane]

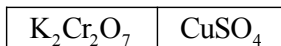

Side X SPM Side Y

Due to osmosis :

- (1) Green colour formation observed on side Y.
(2) Green colour formation observed on side X.
(3) Molarity of $\text{K}_2\text{Cr}_2\text{O}_7$ solution is lowered.
(4) Molarity of CuSO_4 solution is lowered.

Ans. (4)

Sol. Only solvent Molecules are allowed to pass through the SPM.

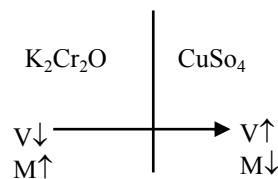

SECTION-B

81. The heat of solution of anhydrous CuSO_4 and $\text{CuSO}_4 \cdot 5\text{H}_2\text{O}$ are -70 kJ mol^{-1} and $+12 \text{ kJ mol}^{-1}$ respectively.

The heat of hydration of CuSO_4 to $\text{CuSO}_4 \cdot 5\text{H}_2\text{O}$ is $-x \text{ kJ}$. The value of x is _____.

Ans. (82)

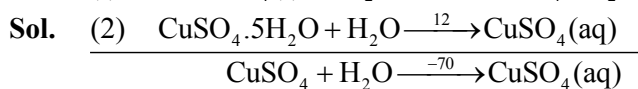

from (1) & (2)

$$-70 = x + 12$$

$$x = -82$$

82. Given below are two statements :

Statement I : The rate law for the reaction $A + B \rightarrow C$ is rate (r) = $k[A]^2[B]$. When the concentration of both A and B is doubled, the reaction rate is increased “x” times.

Statement II :

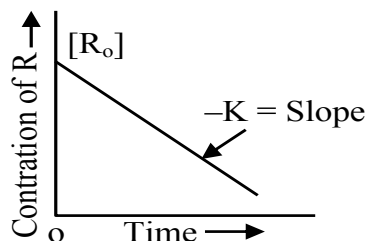

The figure is showing “the variation in concentration against time plot” for a “y” order reaction.

The value of x + y is _____.

Ans. (8)

Sol. $r = k[A]^2[B]$
if conc. are doubled
 $r' = k[2A]^2[2B]^1$
 $r' = 8r \Rightarrow x = 8$

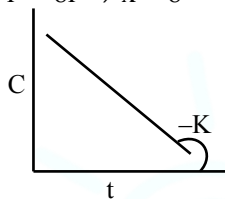

\Rightarrow Zero order, $y = 0$
 $x + y = 8$

83. How many compounds among the following compounds show inductive, mesomeric as well as hyperconjugation effects?

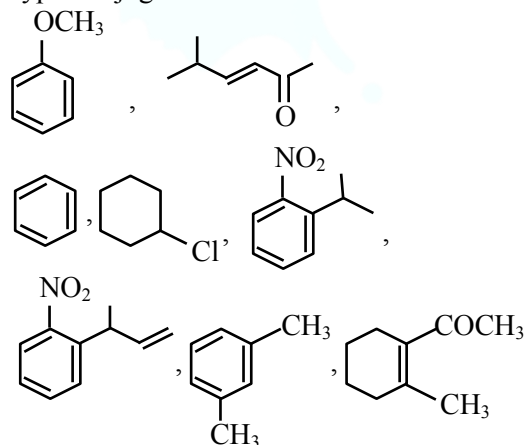

Ans. (4)

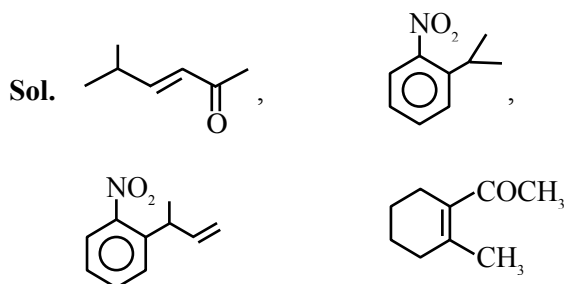

84. The standard reduction potentials at 298 K for the following half cells are given below :

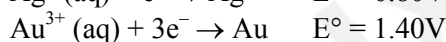
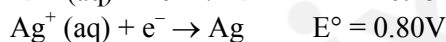
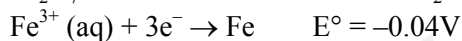
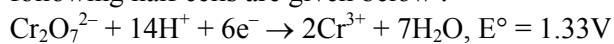

Consider the given electrochemical reactions, The number of metal(s) which will be oxidized by $\text{Cr}_2\text{O}_7^{2-}$, in aqueous solution is _____.

Ans. (3)

Sol. Fe, Ni, Ag will be oxidized due to lower S.R.P.

85. When equal volume of 1M HCl and 1M H_2SO_4 are separately neutralised by excess volume of 1M NaOH solution. X and y kJ of heat is liberated respectively. The value of y/x is _____.

Ans. (2)

Sol. $\text{H}^+ + \text{OH}^- \rightarrow \text{H}_2\text{O} \Rightarrow x$
 $2\text{H}^+ + 2\text{OH}^- \rightarrow 2\text{H}_2\text{O} \Rightarrow 2x = y$
 $y/x = 2$

86. Molarity (M) of an aqueous solution containing x g of anhyd. CuSO_4 in 500 mL solution at 32°C is 2×10^{-1} M. Its molality will be _____ $\times 10^{-3}$ m. (nearest integer).

[Given density of the solution = 1.25 g/mL.]

Ans. (164)

NTA Ans. (81) BONUS

Sol. $M_{\text{sol}^n} = v_{\text{sol}^n} \times d_{\text{sol}^n}$
 $= 500 \times 1.25 = 625\text{g}$
Mass of solute (x) = $0.2 \times 0.5 \times 159.5$
 $= 15.95$

$n_{\text{solute}} = 0.1,$
Mass of solvent = Mass of solution – Mass of solute
 $= 625 - 15.95$
 $= 609.05$
 $m = \frac{0.1}{\frac{609.05}{1000}}$
 $m = 0.164 = 164 \times 10^{-3}$

87. The total number of species from the following in which one unpaired electron is present, is _____.

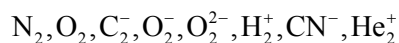

Ans. (4)

Sol. One unpaired e^- is present in : C_2^- ; O_2^- ; H_2^+ ; He_2^+

88. Number of ambidentate ligands among the following is _____.

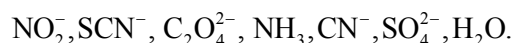

Ans. (3)

Sol. Ligands which have two different donor sites but at a time connects with only one donor site to central metal are ambidentate ligands.

Ambidentate ligands are NO_2^- ; SCN^- ; CN^-

89. Total number of essential amino acid among the given list of amino acids is _____.
Arginine, Phenylalanine, Aspartic acid, Cysteine, Histidine, Valine, Proline

Ans. (4)

Sol. Essential Amino acids are :-
Arginine, Phenylalanine, Histidine, Valine

90. Number of colourless lanthanoid ions among the following is _____.

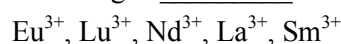

Ans. (2)

Sol. $\text{La}^{+3} - [\text{Xe}]4f^0$

$\text{Nd}^{+3} - [\text{Xe}]4f^3$

$\text{Sm}^{+3} - [\text{Xe}]4f^5$

$\text{Eu}^{+3} - [\text{Xe}]4f^6$

$\text{Lu}^{+3} - [\text{Xe}]4f^{14}$

La^{+3} and Lu^{+3} do not show any colour because no unpaired electron is present.